

ADVANCE DATA

CHARACTERISTICS

GENERAL DATA

Focusing Method	Tri-Potential Electrostatic		
Deflection Method	Magnetic		
Deflection Angles (Approx.)			
Horizontal	105	Degrees	
Diagonal	110	Degrees	
Vertical	87	Degrees	
Phosphor	Aluminized P4		
Fluorescence	White		
Persistence	Short to Medium		
Faceplate	Gray Filter Glass		
Light Transmittance (Approx.)	75	Percent	

ELECTRICAL DATA

Heater Voltage	6.3	Volts	
Heater Current	0.30 ± 5%	Ampere	
Heater Warm-up Time ¹	11	Seconds	
Direct Interelectrode Capacitances (Approx.)			
Cathode to All Other Electrodes	5	µµf	
Grid No. 1 to All Other Electrodes	6	µµf	
External Conductive Coating to Anode ²	2500	µµf Max.	
	2000	µµf Min.	

MECHANICAL DATA

Minimum Useful Screen Dimensions (Maximum Assured)			
Height	15 1/16	Inches	
Width	19 1/16	Inches	
Diagonal	20 1/4	Inches	
Area	262	Sq. Inches	
Neck Length	3 9/16 ± 1/8	Inches	
Overall Length	12 9/16 ± 5/16	Inches	
Bulb	J17H or J17J		
Bulb Contact (Recessed Small Cavity Cap)	J1-21		
Base	B7-208		
Basing	8JR		
Weight (Approx.)	21	Pounds	

QUICK REFERENCE DATA

Television Picture Tube
 21" Direct Viewed
 Rectangular Glass Type
 Spherical Faceplate
 Gray Filter Glass
 Aluminized Screen
 Tri-Potential
 Electrostatic Focus
 110° Magnetic Deflection
 No Ion Trap
 External Conductive
 Coating
 Short Neck
 6.3 Volt, 300 Ma Heater

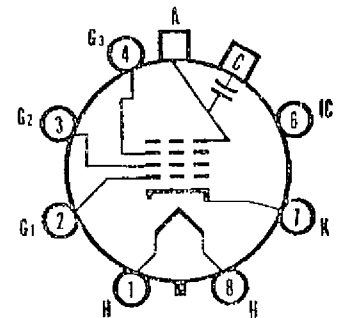
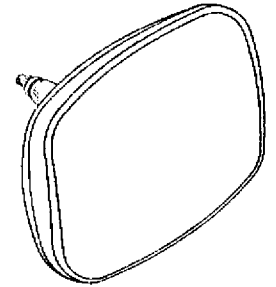

8JR

**SYLVANIA
 ELECTRONIC TUBES**

A Division of
 Sylvania Electric Products Inc.

**PICTURE TUBE OPERATIONS
 SENECA FALLS, NEW YORK**

Prepared and Released By The
 TECHNICAL PUBLICATIONS SECTION
 EMPORIUM, PENNSYLVANIA

March 23, 1959

Page 1 of 3

SYLVANIA

21EXP4

Page 2

RATINGS

MAXIMUM RATINGS (Design Maximum Values) Grid Drive Service

Anode Voltage	20,000	Volts	dc
Grid No. 3 Voltage (Focusing Electrode)	700	Volts	dc
Grid No. 2 Voltage	600	Volts	dc
Grid No. 1 Voltage			
Negative Bias Value	154	Volts	dc
Negative Peak Value	220	Volts	
Positive Bias Value	0	Volts	dc
Positive Peak Value	2	Volts	
Peak Heater-Cathode Voltage			
Heater Negative with Respect to Cathode			
During Warm-up Period not to Exceed 15 Seconds	450	Volts	
After Equipment Warm-up Period	200	Volts	
Heater Positive with Respect to Cathode	200	Volts	

TYPICAL OPERATING CONDITIONS (Grid Drive Service)

Anode Voltage	16,000	Volts	dc
Grid No. 3 Voltage for Focus	0 to +400	Volts	dc
Grid No. 2 Voltage ³	500	Volts	dc
Grid No. 1 Voltage Required for Cutoff ⁴	-43 to -78	Volts	dc

CIRCUIT VALUES

Grid No. 1 Circuit Resistance	1.5	Megohms	Max.
-------------------------------	-----	---------	------

NOTES:

1. Heater warm-up time is defined as the time required for the voltage across the heater to reach 80% of the rated heater voltage after applying four (4) times rated heater voltage to a circuit consisting of the tube heater in series with a resistance equal to three (3) times the rated heater voltage divided by the rated heater current.
2. External conductive coating must be grounded.
3. Brightness and resolution improve with increase in Grid No. 2 voltage. A minimum value of 400 volts is recommended.
4. Visual extinction of focused raster. Extinction of stationary focused spot will require that these values be about 5 volts more negative.

WARNING:

X-ray radiation shielding may be necessary to protect against possible danger of personal injury from prolonged exposure at close range if this tube is operated at higher than the manufacturer's Maximum Rated Anode Voltage or 16,000 volts, whichever is less.

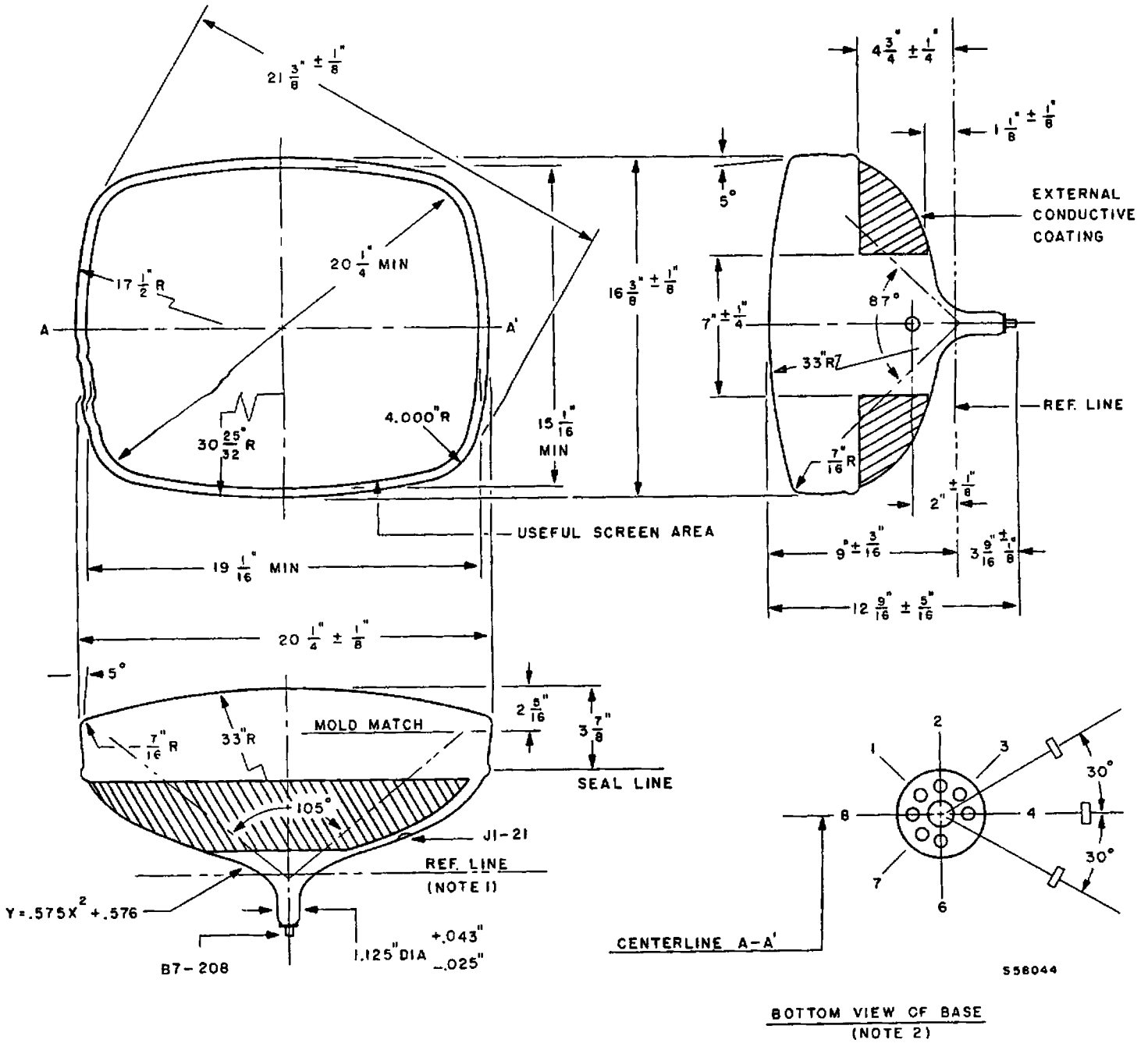

DIAGRAM NOTES:

- Reference line is determined by plane C-C¹ of JETEC No. 126 Reference Line Gauge, when the gauge is seated against the bulb.
- Base Pin No. 4 aligns with horizontal centerline (A-A') within 30° and is on same side as anode contact, J1-21.