

# engineering TUBE DATA

KUTHE  
\* 7583

from JEDEC release #3993,  
Nov. 26, 1962



*Components Division*

DESCRIPTION:

THE 7583 IS A UNIPOTENTIAL CATHODE, THREE ELEMENT HYDROGEN FILLED THYRATRON DESIGNED FOR NETWORK DISCHARGE SERVICE. IN SUCH SERVICE IT IS SUITABLE FOR PRODUCING PULSE OUTPUTS OF MORE THAN 140 KW AT AN AVERAGE POWER OF MORE THAN 150 WATTS. IT IS ESPECIALLY SUITABLE FOR COMPACT, AIRBORNE RADAR SYSTEMS.

ELECTRICAL DATA, GENERAL:

	<u>NOM.</u>	<u>MIN.</u>	<u>MAX.</u>	
HEATER VOLTAGE	6.3	5.6	6.6	VOLTS AC
HEATER CURRENT (AT 6.3 VOLTS)		2.0	2.5	AMPERES
MINIMUM HEATING TIME				2.0 MINUTES

MECHANICAL DATA, GENERAL:

MOUNTING POSITION		ANY
BASE		PER OUTLINE
COOLING (NOTE 1)		
NET WEIGHT	0.3	POUNDS
DIMENSIONS		PER OUTLINE

RATINGS:

MAX. PEAK ANODE VOLTAGE, FORWARD	8.0	KILOVOLTS
MAX. PEAK ANODE VOLTAGE, INVERSE (NOTE 2)	8.0	KILOVOLTS
MIN. ANODE SUPPLY VOLTAGE	2.5	KILOVOLTS DC
MAX. PEAK ANODE CURRENT	35	AMPERES
MAX. AVERAGE ANODE CURRENT	45	MILLIAMPERES
MAX. RMS ANODE CURRENT (NOTE 3)	1.25	AMPERES AC
MAX. EPY X IB X PRR	1.1 x 10 <sup>9</sup>	
MAX. ANODE CURRENT RATE OF RISE	1200	AMPS. / U SEC.
PEAK TRIGGER VOLTAGE (NOTE 4)		
MAX. ANODE DELAY TIME (NOTE 5)	0.60	MICROSECOND
MAX. ANODE DELAY TIME DRIFT	0.15	MICROSECOND
MAX. TIME JITTER (NOTE 6)	0.005	MICROSECOND
AMBIENT TEMPERATURE	-50 TO / 90	C

\* THIS TUBE WAS PREVIOUSLY DESIGNATED BY TYPE NUMBER KII-82.



ELECTRON TUBE DEPARTMENT  
**COMPONENTS DIVISION**  
INTERNATIONAL TELEPHONE AND TELEGRAPH CORPORATION

6-61

P. O. BOX 412, CLIFTON, NEW JERSEY

NOTE 1:

COOLING OF THE ANODE LEAD IS PERMISSIBLE, BUT THERE SHALL BE NO AIR BLAST DIRECTLY ON THE BULB.

NOTE 2:

IN PULSED OPERATION, THE PEAK INVERSE VOLTAGE, EXCLUSIVE OF SPIKE OF .05 US MAXIMUM DURATION, SHALL NOT EXCEED 3000 V DURING THE FIRST 25 US AFTER THE PULSE.

NOTE 3:

THE ROOT MEAN SQUARE ANODE CURRENT SHALL BE COMPUTED AS THE SQUARE ROOT OF THE PRODUCT OF THE PEAK CURRENT AND THE AVERAGE CURRENT.

NOTE 4:

DRIVER PULSE, MEASURED AT TUBE SOCKET WITH THYRATRON GRID DISCONNECTED; EGY = 175 V (MIN), TIME OF RISE = 0.5 US (MAX), GRID PULSE DURATION = 2 US (MIN). IMPEDANCE OF DRIVE CIRCUIT = 1500 OHMS (MAX).

NOTE 5:

THE TIME OF ANODE DELAY IS MEASURED BETWEEN THE 26 PERCENT POINT ON THE RISING PORTION OF THE UNLOADED GRID VOLTAGE PULSE AND THE POINT AT WHICH EVIDENCE OF ANODE CONDUCTION FIRST APPEARS ON THE LOADED GRID PULSE.

NOTE 6:

TIME JITTER IS MEASURED AT THE 50 PERCENT POINT ON THE ANODE CURRENT PULSE.

ADDITIONAL INFORMATION FOR SPECIFIC APPLICATIONS CAN BE OBTAINED FROM THE

ELECTRON TUBE APPLICATIONS SECTION  
ITT COMPONENTS DIVISION  
POST OFFICE Box 412  
CLIFTON, NEW JERSEY

OUTLINE

KUTHE  
7583

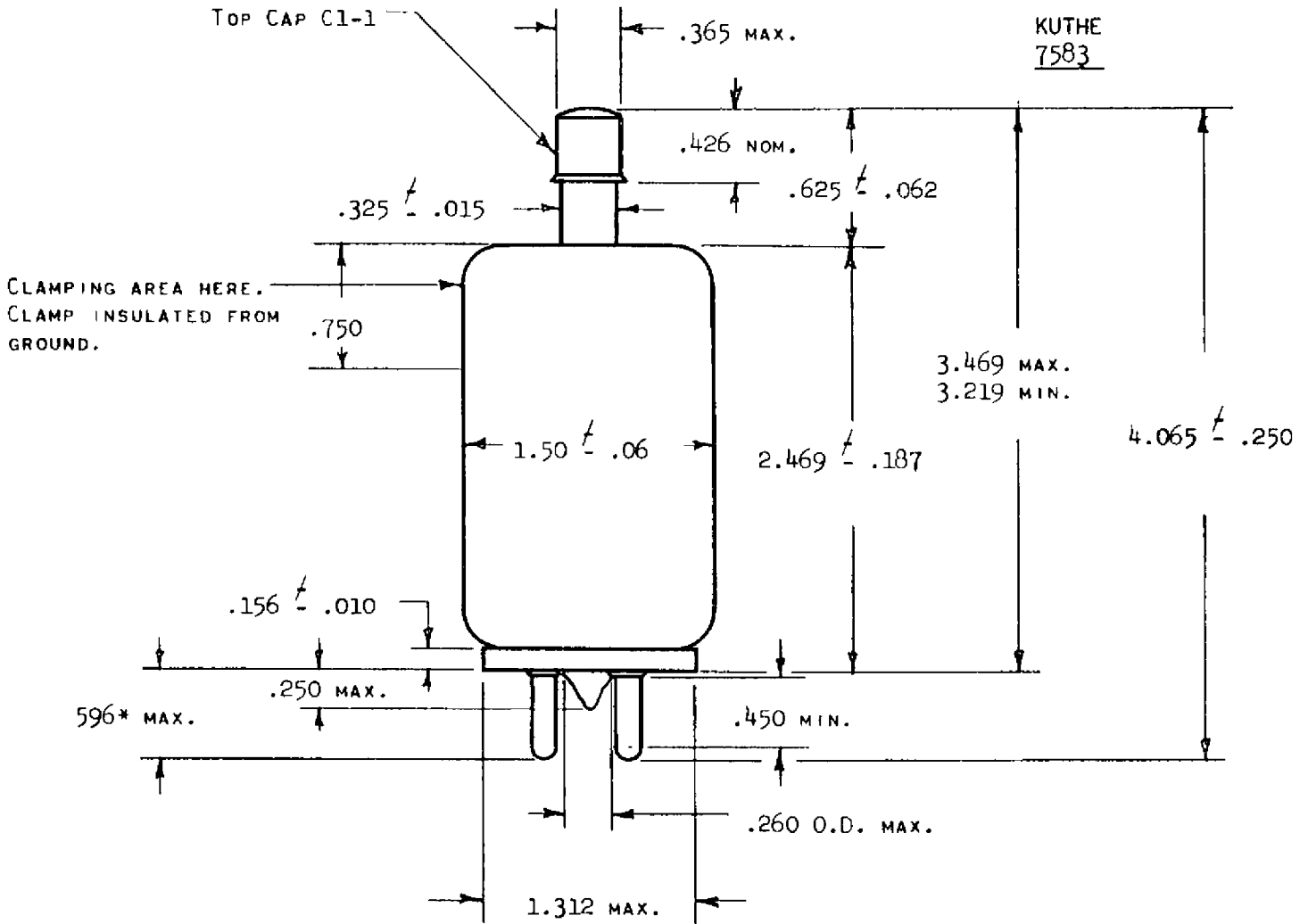

OUTLINE

\* ON FINISHED TUBE ADD .030 FOR SOLDER

KUTHE KU-82

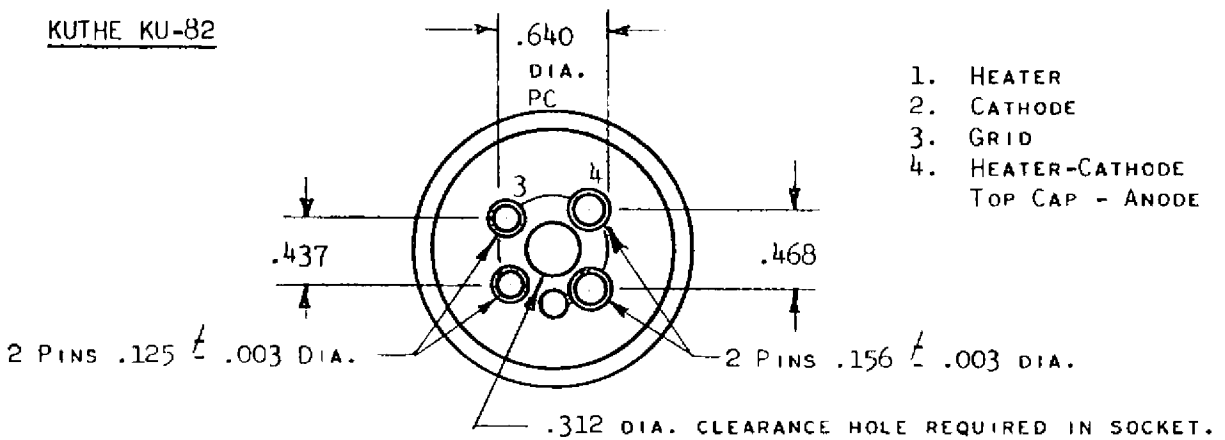

WAFER BASE. PIN ARRANGEMENT AND DIMENSIONS ONLY AS PER A4-9 MIL-E-1C