

# Multiplier Phototube

## S-11 RESPONSE

"RUGGEDIZED", 10-STAGE, HEAD-ON, ELECTROSTATICALLY FOCUSED  
FLAT-FACEPLATE TYPE IN-LINE DYNODE STAGES

For Detection and Measurement of Nuclear-  
Radiation and Low-Level Light in Com-  
pact Industrial and Military Equipment

### General:

Spectral Response . . . . .	S-11
Wavelength of Maximum Response . . . . .	4400 ± 500 angstroms
Cathode, Semitransparent . . . . .	Cesium-Antimony
Minimum area . . . . .	0.2 sq. in.
Minimum diameter . . . . .	0.5 in.
Window . . . . .	Lime Glass (Corning <sup>a</sup> No.0080), or equivalent
Shape . . . . .	Plano-Concave
Index of refraction at 5893 angstroms. . . . .	1.51
Dynode Material. . . . .	Copper-Beryllium
Direct Interelectrode Capacitances (Approx.):	
Anode to dynode No.10. . . . .	2.4 pf
Anode to all other electrodes. . . . .	3.2 pf
Maximum Overall Length	
(Excluding semiflexible leads) . . . . .	3.38"
Maximum Diameter . . . . .	0.78"
Operating Position . . . . .	Any
Weight (Approx.) . . . . .	0.9 oz
Bulb . . . . .	T6
Magnetic Shield. . . . .	Perfection Mica Co. <sup>b</sup> , or equivalent
Base . . . . .	Small-Button Thirteenar 12-Semiflexible Lead, (JEDEC No.E12-72), and Protective Shell
Basing Designation for BOTTOM VIEW . . . . .	12BG

- Lead 1 - Dynode No.1
- Lead 2 - Dynode No.3
- Lead 3 - Dynode No.5
- Lead 4 - Dynode No.7
- Lead 5 - Dynode No.9
- Lead 6 - Anode
- Lead 7 - Dynode No.10
- Lead 8 - Dynode No.8
- Lead 9 - Dynode No.6
- Lead 10 - Dynode No.4
- Lead 11 - Dynode No.2
- Lead 12 - Photocathode

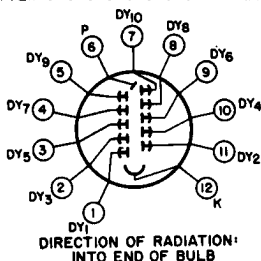

### Maximum Ratings, Absolute-Maximum Values:

Supply Voltage (DC or Peak AC):		
Between Anode and Cathode. . . . .	1500 max.	volts
Between Anode and Dynode No.10 . . . . .	300 max.	volts
Between Consecutive Dynodes. . . . .	250 max.	volts
Between Dynode No.1 and Cathode. . . . .	400 max.	volts
Average Anode Current <sup>c</sup> . . . . .	0.5 max.	ma
Ambient Temperature. . . . .	75 max.	°C



### Characteristics Range Values:

Under conditions with dc supply voltage (E) across a voltage divider providing 1/6 of E between cathode and dynode No. 1; 1/12 of E for each succeeding dynode stage; and 1/12 of E between dynode No. 10 and anode

With E = 1250 volts (Except as noted)

	Min.	Typ.	Max.	
Sensitivity:				
Radiant, at 4400 angstroms. . . . .	-	$6 \times 10^3$	-	a/w
Cathode radiant, at 4400 angstroms. . .	-	0.048	-	a/w
Luminous, At 0 cps <sup>d</sup> . . . . .	3	7.5	60	a/lm
Cathode luminous:				
With tungsten light source <sup>e</sup> . . . . .	$4 \times 10^{-5}$	$6 \times 10^{-5}$	-	a/lm
With blue light source <sup>f, g</sup> . . . . .	$4 \times 10^{-8}$	$6 \times 10^{-8}$	-	a
Current Amplification. . .	-	$1.25 \times 10^5$	-	
Equivalent Anode-Dark-Current Input at a luminous sensitivity of 7.5 a/lm <sup>h</sup> . . . . .	-	$8 \times 10^{-10}$	$2 \times 10^{-9}$	lm
Equivalent Noise Input <sup>j</sup> . . .	-	$3 \times 10^{-12}$	$1 \times 10^{-11}$	lm
Anode-Pulse Rise Time <sup>k</sup> . . .	-	$2.1 \times 10^{-9}$	-	sec
Electron Transit Time <sup>m</sup> . . .	-	$2.3 \times 10^{-8}$	-	sec
Quantum Efficiency at 4300 angstroms. . . . .	-	14	-	%

<sup>a</sup> Made by Corning Glass Works, Corning, New York.

<sup>b</sup> Magnetic shielding in the form of foil or tape as available from the Magnetic Shield Division, Perfection Mica Company, 1322 North Ellston, Chicago 24, Illinois, or equivalent.

<sup>c</sup> Averaged over any interval of 30 seconds maximum.

<sup>d</sup> Under the following conditions: The light source is a tungsten-filament lamp having a lime-glass envelope. It is operated at a color temperature of 2870° K and a light input of 10 microlumens is used.

<sup>e</sup> Under the following conditions: The light-source is a tungsten-filament lamp having a lime-glass envelope. It is operated at a color temperature of 2870° K. The value of light flux is 0.01 lumen and 200 volts are applied between cathode and all other electrodes connected as anode.

<sup>f</sup> Under the following conditions: Light incident on the cathode is transmitted through a blue filter (Corning C.S. No. 5-5B, polished to 1/2 stock thickness—Manufactured by the Corning Glass Works, Corning, New York) from a tungsten-filament lamp operated at a color temperature of 2870° K. The value of light flux incident on the filter is 0.01 lumen and 200 volts are applied between cathode and all other electrodes connected as anode.

<sup>g</sup> See *Spectral Characteristic of 2870° K Light Source and Spectral Characteristic of Light from 2870° K Source after passing through Indicated Blue Filter* at front of this Section.

<sup>h</sup> At a tube temperature of 25° C. Darkcurrent may be reduced by use of a refrigerant such as dry ice.

<sup>j</sup> Under the following conditions: Supply voltage (E) is as shown, 25° C tube temperature, external shield connected to cathode, bandwidth 1 cycle per second, tungsten-light source at a color temperature of 2870° K interrupted at a low audio frequency to produce incident radiation pulses alternating between zero and the value stated. The "on" period of the pulse is equal to the "off" period.

- k Measured between 10 per cent and 90 per cent of maximum anode-pulse height. This anode-pulse rise time is primarily a function of transit-time variation and is measured under conditions with the incident light fully illuminating the photocathode.
- m The electron transit time is the time interval between the arrival of a delta function light pulse at the entrance window of the tube and the time at which the output pulse at the anode terminal reaches peak amplitude. The transit time is measured under conditions with the incident light fully illuminating the photocathode.

**SPECTRAL-SENSITIVITY CHARACTERISTIC  
OF PHOTSENSITIVE DEVICE HAVING S-II RESPONSE  
is shown at the front of this Section**

**ENVIRONMENTAL TESTS-**

The 4460 is designed to withstand the shock, vibration, and acceleration tests shown below which are equivalent to those specified in MIL-E-5272C\* for equipment mounted on the structures of missiles propelled or launched by high-thrust rocket engines. The accelerations specified in these tests are applied directly to the tubes.

**One-Hundred Per-Cent Shock and Vibration Testing:**

Each 4460 is subjected in sequence to shock and then to vibration as specified below with the tube non-operating.

**Shock.** These tests are performed first, per method of MIL-E-5272C\*, Paragraph 4.15.5.1, Procedure V, on apparatus which provides a half-wave sinusoidal shock pulse. One-hundred per-cent testing of all 4460's is performed. Each 4460 is subjected to three impact shocks in each direction of the three orthogonal axes shown in the accompanying *Orthogonal Axes Used During Environmental Tests* drawing. The peak acceleration of the impact shock is  $30 \pm 3$  g's and the time duration is  $11 \pm 1$  milliseconds. Each tube is subjected to a total of 18 impact shocks.

**Vibration.** These tests are performed next, on apparatus which applies variable-sinusoidal frequency vibration to the tube, per method of MIL-E-5272C\*, paragraph 4.7.14 and paragraph 4.7.14.1. One-hundred per-cent testing of all 4460's is performed. Each 4460 is vibrated in each of the three orthogonal axes shown in the accompanying *Orthogonal Axes Used During Environmental Tests* drawing and as specified in the schedule below. A vibration cycle has a duration of 5 minutes per axis in which time the frequency is varied logarithmically from 20 to 2000 and back to 20 cycles per second. One vibration cycle is performed for each axis and the total test period for each tube is 15 minutes.

Double Amplitude Inches	Acceleration g's	Frequency cps	Cycle Duration per axis minutes
0.050 $\pm$ 0.005	-	20 - 87	} 5
-	20 $\pm$ 2	87 - 2000	
-	20 $\pm$ 2	2000 - 87	
0.050 $\pm$ 0.005	-	87 - 20	



**Tube Rejection Criterion.** Upon completion of the *One-Hundred Per-Cent Shock and Vibration Testing* each tube is tested at a anode-to-cathode voltage of 1250 volts under the conditions shown under *Characteristics Range Values for Equipment Design* and will meet the specified values.

## Design Tests:

**Vibration.** These tests are performed under conditions equivalent to those described in MIL-E-5272C\*, paragraph 4.7.14 and paragraph 4.7.14.1. The vibration cycle has a duration of one hour and two cycles are performed for each of the three orthogonal axes shown in the accompanying *Orthogonal Axes Used During Environmental Tests* drawing. The total test period for each tube is six hours. Tubes are operating during the test.

**Acceleration.** These tests are performed in a centrifuge providing unidirectional acceleration by a method equivalent to that specified in MIL-E-5272C\*, paragraph 4.16.3, Procedure III, except that tubes are subjected for one minute to an increased acceleration test level of  $100 \pm 10$  g's in both directions of the three orthogonal axes shown in the accompanying *Orthogonal Axes Used During Environmental Tests* drawing and the tubes are non-operating.

\* Military Specification MIL-E-5272C (ASG), 13 April 1959; and Amendment 1, 5 January 1960.

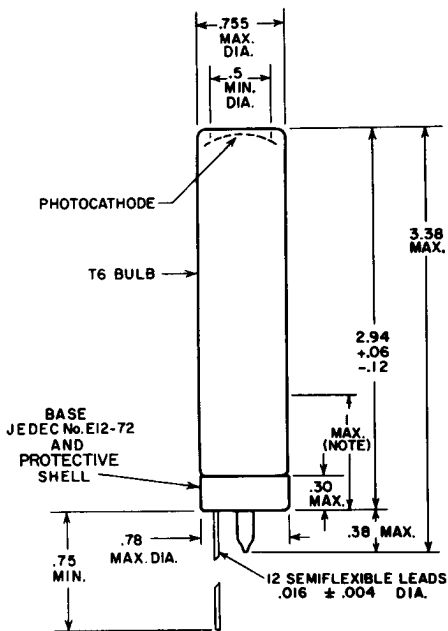

DIMENSIONS IN INCHES

Note: Within this length, maximum diameter of tube is 0.78".

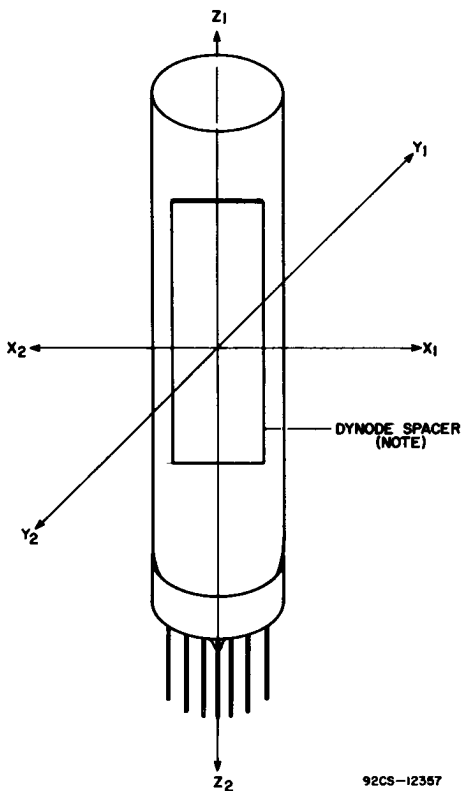

ORTHOGONAL AXES USED  
DURING ENVIRONMENTAL TESTS

92CS-12357

**Note:** The plane of each dynode spacer is parallel to the X-Z plane. The Z-axis is the major axis of the tube.

## TYPICAL VOLTAGE-DIVIDER ARRANGEMENT

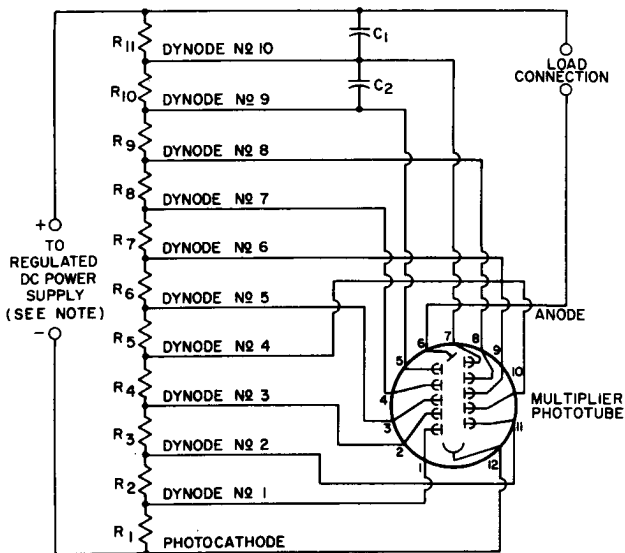

92CS-10656R1

**Note:** Adjustable between approximately 500 and 1500 volts DC.

$C_1, C_2$ : 0.01  $\mu$ f, 500 volts (dc working)

$R_1$ : 91,000 ohms, 2 watts

$R_2$  through  $R_{11}$ : 47,000 ohms, 1 watt



## AVERAGE ANODE CHARACTERISTICS

DYNODE-N<sub>2</sub>1-TO-CATHODE VOLTS = 208  
 EACH SUCCEEDING-DYNODE-STAGE VOLTS = 104  
 LIGHT SOURCE IS A TUNGSTEN-FILAMENT LAMP  
 OPERATED AT COLOR TEMPERATURE OF  
 2870° K.

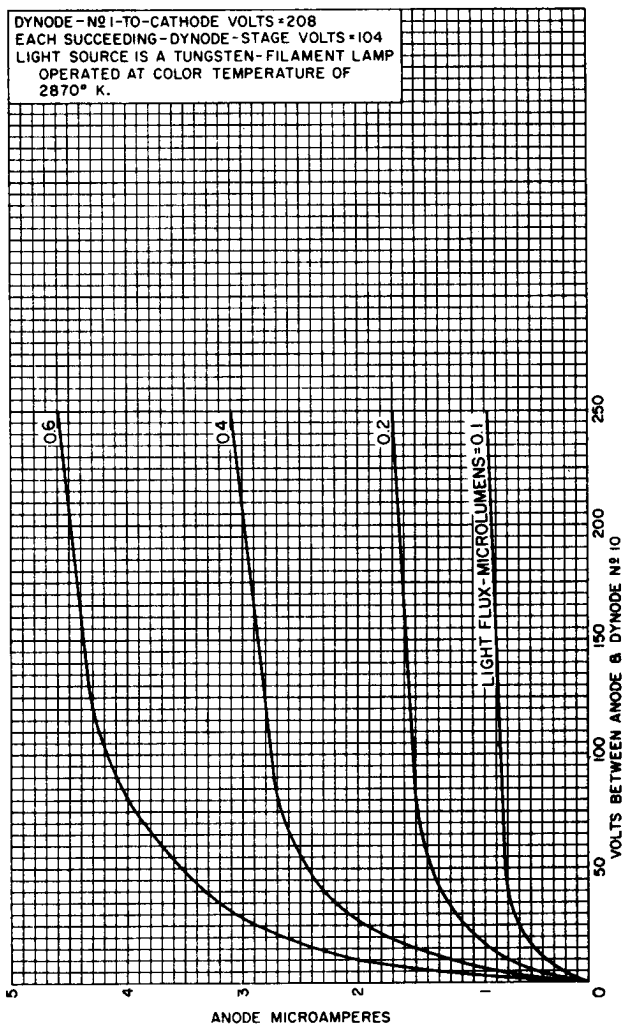

92CM-10660



## SENSITIVITY AND CURRENT AMPLIFICATION CHARACTERISTICS

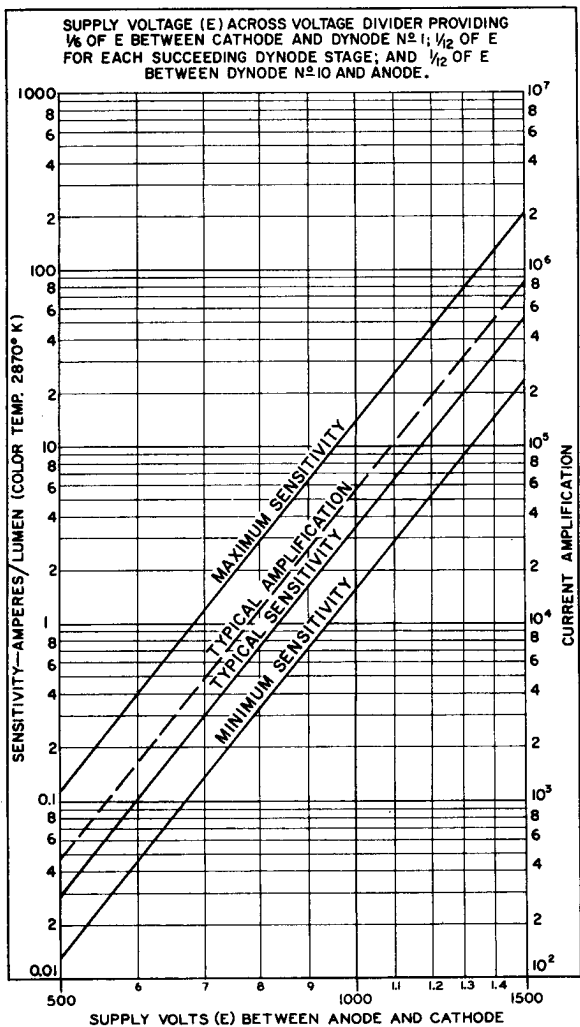

## TYPICAL ANODE-DARK-CURRENT CHARACTERISTIC

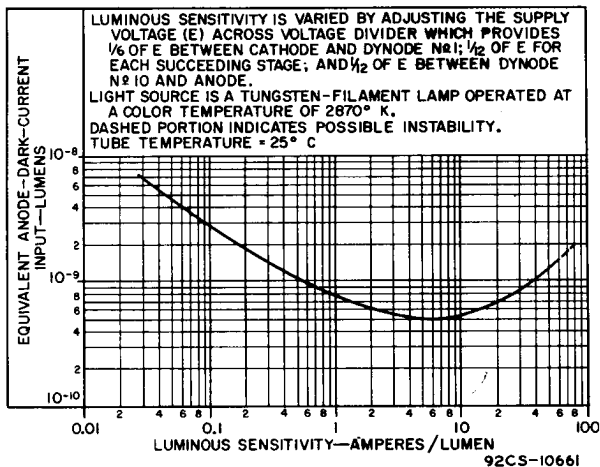

## TYPICAL TIME RESOLUTION CHARACTERISTICS

