



6383

6383

POWER TRIODE

LIQUID AND FORCED-AIR COOLED

Full Input at Frequencies Up to 2000 Mc

GENERAL DATA

Electrical:

Heater, for Unipotential Cathode:

Voltage*	6.3 av.	ac or dc volts
	6.9 max.	volts
Current	3.4	amp
Minimum heating time	1	minute

Amplification Factor 27

Direct Interelectrode Capacitances:

Grid to plate	6	$\mu\mu\text{f}$
Grid to cathode	11	$\mu\mu\text{f}$
Plate to cathode*	0.22	$\mu\mu\text{f}$

Mechanical:

Terminal Connections:

H - Heater Terminals
(Center Pin at
Cathode End &
Cath. Terminal)

K - Cathode Terminal
(End Opposite Pipes)

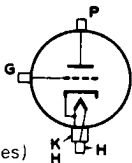

G - Grid Terminal
(Between Plate
Flange and
Cath. Terminal)

P - Plate Terminal
(Plate Flange)

Mounting Position	Any
Overall Length	4-3/16" \pm 3/32"
Greatest Diameter	1.750" \pm 0.010"
Cooling Jacket	Integral part of tube
Mounting	Special

Air Cooling:

Forced-air cooling of the grid terminal, cathode terminal, and glass envelope is required. The air flow must start with the application of any voltages, and be adequate to limit the temperature of the grid terminal, cathode terminal, and glass envelope to their respective maximum values. Heater power, plate power, and air flow may be removed simultaneously.

Liquid Cooling:

Liquid cooling of the plate is required. The liquid flow must start before the application of any voltages. Interlocking of the liquid flow with all power supplies is recommended to prevent tube damage in case of failure of adequate liquid flow. Suitable coolants are: Distilled Water, Butyl Carbitol, Ethylene Glycol, Monsanto OS45 (High Temperature Hydraulic Fluid), and Dow Corning No. 200 Fluid.

Liquid-coolant pressure	60 max.	psi
Water flow required:		
With plate dissipation of 300 watts	0.25 min.	gpm
With plate dissipation of 600 watts	0.4 min.	gpm

* with external flat shield 7-1/2" minimum diameter located in plane of the grid terminal and perpendicular to axis of tube. Shield is connected to grid terminal.

*: See next page.

6383



6383

POWER TRIODE

Water flow obtained:

With pressure drop of 0.5 psi	0.25 min.	gpm
With pressure drop of 2.0 psi	0.4 min.	gpm
Outlet water temperature	70 max.	°C

For coolants other than water, the flow required, the pressure drop, and the outlet coolant temperature will depend on the characteristics of the coolant.

Plate Temperature (Measured on side of plate flange opposite the pipes and at junction of flange with tube body) . . .	180 max.	°C
Grid-Terminal Temperature	200 max.	°C
Cathode-Terminal Temperature	200 max.	°C
Glass-Envelope Temperature	175 max.	°C
Weight (Aporox.)	8	ounces

AF POWER AMPLIFIER & MODULATOR--Class A

Maximum CCS* Ratings, Absolute Values:

DC PLATE VOLTAGE	1500 max.	volts
DC GRID VOLTAGE	-300 max.	volts
DC PLATE CURRENT	400 max.	ma
DC GRID CURRENT	75 max.	ma
PLATE INPUT	600 max.	watts
PLATE DISSIPATION	600 max.	watts

Typical Operation (Class A₁):

DC Plate Voltage	1000	1500	volts
DC Grid Voltage	-25	-40	volts
Peak AF Grid Voltage	20	35	volts
DC Plate Current	200	250	ma
Load Resistance	1350	1550	ohms
Power Output	20	60	watts

PLATE-MODULATED RF POWER AMP.--Class C Telephony

Carrier conditions per tube for use with a max. modulation factor of 1.0

Maximum CCS* Ratings, Absolute Values:

DC PLATE VOLTAGE	1200 max.	volts
DC GRID VOLTAGE	-300 max.	volts
DC PLATE CURRENT	335 max.	ma
DC GRID CURRENT	See Rating Chart	
PLATE INPUT	400 max.	watts
PLATE DISSIPATION	400 max.	watts

* Values are based on maximum power output disregarding distortion.

*. See next page.



6383

6383

POWER TRIODE

Typical Operation:

<i>In Cathode-Drive Circuit at</i>		600 Mc	1000 Mc	
Heater Voltage*		5.7	4.5	volts
DC Plate-to-Grid Voltage . . .		1340	1315	volts
DC Cathode-to-Grid Voltage . .		140	115	volts
<i>From cathode resistor of</i> [▲]		380	330	ohms
Peak RF Cathode-to-Grid Voltage		200	175	volts
DC Plate Current		335	335	ma
DC Grid Current (Approx.) . . .		35	15	ma
Driver Power Output (Approx.) ^{◆◆}		70	76	watts
Output-Circuit Efficiency (Approx.) . .		80	60	per cent
Useful Power Output (Approx.) .		250 ⁰⁰	190 ⁰⁰	watts
<i>In Cathode-Drive Circuit at</i>		1100 Mc	1500 Mc	
Heater Voltage*		4.5	4.5	volts
DC Plate-to-Grid Voltage . . .		1290	1280	volts
DC Cathode-to-Grid Voltage . .		90	80	volts
<i>From cathode resistor of</i> [▲]		260	235	ohms
Peak RF Cathode-to-Grid Voltage		145	130	volts
DC Plate Current		335	335	ma
DC Grid Current (Approx.) . . .		12	4	ma
Driver Power Output (Approx.) ^{◆◆}		80	53	watts
Output-Circuit Efficiency (Approx.) . .		55	50	per cent
Useful Power Output (Approx.) .		160 ⁰⁰	100 ⁰⁰	watts

RF POWER AMPLIFIER & OSC.--Class C Telegraphy[□]
and

RF POWER AMPLIFIER--Class C FM Telephony

Maximum CCS[●] Ratings, Absolute Values:

DC PLATE VOLTAGE	1500 max.	volts
DC GRID VOLTAGE	-300 max.	volts
DC PLATE CURRENT	400 max.	ma
DC GRID CURRENT	See Rating Chart	
PLATE INPUT	600 max.	watts
PLATE DISSIPATION	600 max.	watts

Typical Operation:

<i>As Amplifier in Cathode-Drive Circuit at</i>		600 Mc	1000 Mc	
Heater Voltage*		5.7	4.5	volts
DC Plate-to-Grid Voltage . . .		1640	1615	volts

[■] In cathode-drive, plate-modulated class C rf power amplifier service, the 6383 can be modulated 100% if the rf driver stage is also modulated 100% simultaneously. Care should be taken to insure that the driver-modulation and amplifier-modulation voltages are exactly in phase.

[□] key-down conditions per tube without amplitude modulation. Modulation essentially negative may be used if the positive peak of the audio-frequency envelope does not exceed 115% of the carrier conditions.

* , ▲ , ◆ , 00: See next page.

6383



6383

POWER TRIODE

	600 Mc	1000 Mc	
DC Cathode-to-Grid Voltage . .	140	115	volts
From cathode resistor of [▲] . .	315	275	ohms
Peak RF Cathode-to-Grid Voltage	210	185	volts
DC Plate Current	400	400	ma
DC Grid Current (Approx.) . . .	25	20	ma
Driver Power Output (Approx.) [●]	90	95	watts
Output-Circuit Efficiency (Approx.) . .	80	60	per cent
Useful Power Output (Approx.)	380 ^{oo}	285 ^{oo}	watts
<i>As Amplifier in</i>			
<i>Cathode-Drive Circuit at</i>			
	1100 Mc	1500 Mc	
Heater Voltage*	4.5	4.5	volts
DC Plate-to-Grid Voltage . . .	1590	1580	volts
DC Cathode-to-Grid Voltage . .	90	80	volts
From cathode resistor of [▲] . .	220	200	ohms
Peak RF Cathode-to-Grid Voltage	155	140	volts
DC Plate Current	400	400	ma
DC Grid Current (Approx.) . . .	15	5	ma
Driver Power Output (Approx.) [●]	80	85	watts
Output-Circuit Efficiency (Approx.) . .	55	50	per cent
Useful Power Output (Approx.)	240 ^{oo}	150 ^{oo}	watts
<i>As Oscillator in</i>			
<i>Cathode-Drive Circuit at</i>			
	600 Mc	1000 Mc	
Heater Voltage*	5.7	4.5	volts
DC Plate-to-Grid Voltage . . .	1640	1615	volts
DC Cathode-to-Grid Voltage . .	140	115	volts
From cathode resistor of [▲] . .	315	275	ohms
Peak RF Cathode-to-Grid Voltage	175	140	volts
DC Plate Current	400	400	ma
DC Grid Current (Approx.) . . .	45	20	ma
Output-Circuit Efficiency (Approx.) . .	80	60	per cent
Useful Power Output (Approx.)	280 ^{oo}	190 ^{oo}	watts
<i>As Oscillator in</i>			
<i>Cathode-Drive Circuit at</i>			
	1100 Mc	1500 Mc	
Heater Voltage*	4.5	4.5	volts
DC Plate-to-Grid Voltage . . .	1590	1580	volts
DC Cathode-to-Grid Voltage . .	90	80	volts
From cathode resistor of [▲] . .	220	200	ohms
Peak RF Cathode-to-Grid Voltage	120	110	volts
DC Plate Current	400	400	ma
DC Grid Current (Approx.) . . .	15	5	ma
Output-Circuit Efficiency (Approx.) . .	55	50	per cent
Useful Power Output (Approx.)	150 ^{oo}	60 ^{oo}	watts

*, ●, ▲, °: See next page.



6383

6383

POWER TRIODE

FREQUENCY MULTIPLIER--Class C

Maximum CCS* Ratings, Absolute Values:

DC PLATE VOLTAGE	1500 max.	volts
DC GRID VOLTAGE	-300 max.	volts
DC PLATE CURRENT	400 max.	ma
DC GRID CURRENT	See Rating Chart	
PLATE INPUT	600 max.	watts
PLATE DISSIPATION	600 max.	watts

Typical Operation in Cathode-Drive Circuit:

	Doubler to 600 Mc	Doubler to 900 Mc	
DC Plate-to-Grid Voltage . . .	1760	1675	volts
DC Cathode-to-Grid Voltage . .	260	175	volts
From cathode resistor of [▲] . .	570	415	ohms
Peak RF Cathode-to-Grid Voltage . . .	300	215	volts
DC Plate Current	400	400	ma
DC Grid Current (Approx.) . . .	55	25	ma
Driver Power Output (Approx.) [*] . .	195	160	watts
Output-Circuit Efficiency (Approx.) . . .	80	60	per cent
Useful Power Output (Approx.) . . .	280 ^{oo}	225 ^{oo}	watts

CHARACTERISTICS RANGE VALUES FOR EQUIPMENT DESIGN

	Note	Min.	Max.	
Heater Current	1	3.05	3.75	amp
Amplification Factor	1,2	20	34	
Grid-Plate Capacitance	-	5.5	6.5	μf
Grid-Cathode Capacitance	-	9.6	12.4	μf
Plate-Cathode Capacitance	3	0.12	0.32	μf
Plate Voltage (1)	1,4	550	810	volts
Plate Voltage (2)	1,5	750	1150	volts
Grid Voltage	1,6	-	-165	volts
Peak Cathode Current	1,7	9	-	amp
Useful Power Output	8,9	140	-	watts

Note 1: With 6.3 volts ac on heater.

Note 2: With dc grid voltage of -15 volts, and dc plate voltage adjusted to give dc plate current of 250 milliamperes.

Note 3: With external shield as described under (●).

Note 4: With dc grid voltage of -10 volts, and dc plate voltage adjusted to give dc plate current of 250 milliamperes.

Note 5: With dc grid voltage of -20 volts, and dc plate voltage adjusted to give dc plate current of 250 milliamperes.

Note 6: With dc plate voltage of 1500 volts, and dc grid voltage adjusted to give dc plate current of 1.0 milliampere.

*, ●, ▲, ○, °: See next page.

AUG. 16, 1954

TUBE DIVISION

TENTATIVE DATA 3

RADIO CORPORATION OF AMERICA, HARRISON, NEW JERSEY

6383



6383

POWER TRIODE

Note 7: Designers should limit the maximum useable cathode current (plate current and grid current) to this value under any condition of operation.

Note 8: With 4.5 volts ac on heater.

Note 9: In a self-excited, cathode-drive oscillator circuit and with dc plate-to-grid voltage of 1570 to 1625 volts (in all cases, plate-to-cathode voltage is 1500 volts), dc plate current of 400 ma., dc grid current of -10 to +50 ma., cathode-to-grid voltage of 70 to 125 volts, and frequency of 1100 Mc.

* Operation should always be started with a heater voltage of 6.3 volts. Because the cathode is subjected to considerable back bombardment as the frequency is increased with resultant increase in temperature, the heater voltage should be reduced in accord with the following table to prevent overheating the cathode and resultant short life.

<i>Approx. Frequency Range Mc</i>	<i>Heater Volts</i>
Up to 550-600	6.3
550 to 750-800	5.7
750 to 975-1025	5.1
975 and above	4.5

• Continuous Commercial Service.

▲ At frequencies below 600 Mc, it is permissible to use a combination of grid and cathode resistors, but the use of a grid resistor alone is not recommended. At frequencies above 600 Mc where the value of grid current may be small, only cathode bias is recommended.

• The driver stage is required to supply tube losses, rf circuit losses, and rf power added to plate input. The driver stage should be designed to provide an excess of power above the indicated value to take care of variations in line voltage, in components, in initial tube characteristics, and in tube characteristics during life.

oo This value of useful power is measured at load of output circuit having indicated efficiency.

RATING CHART

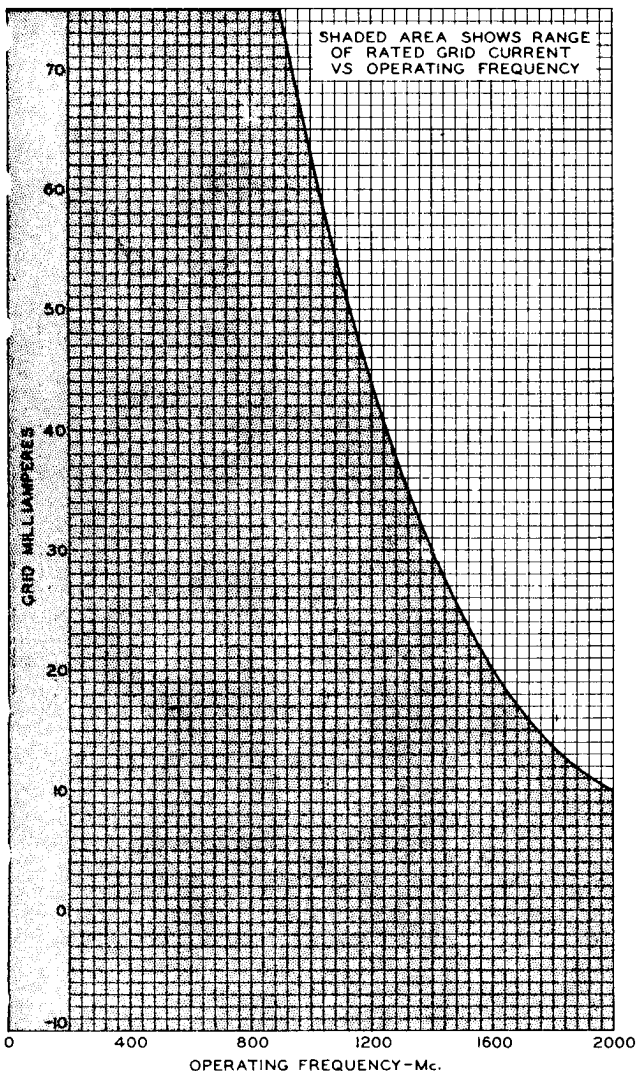

6383



6383

POWER TRIODE

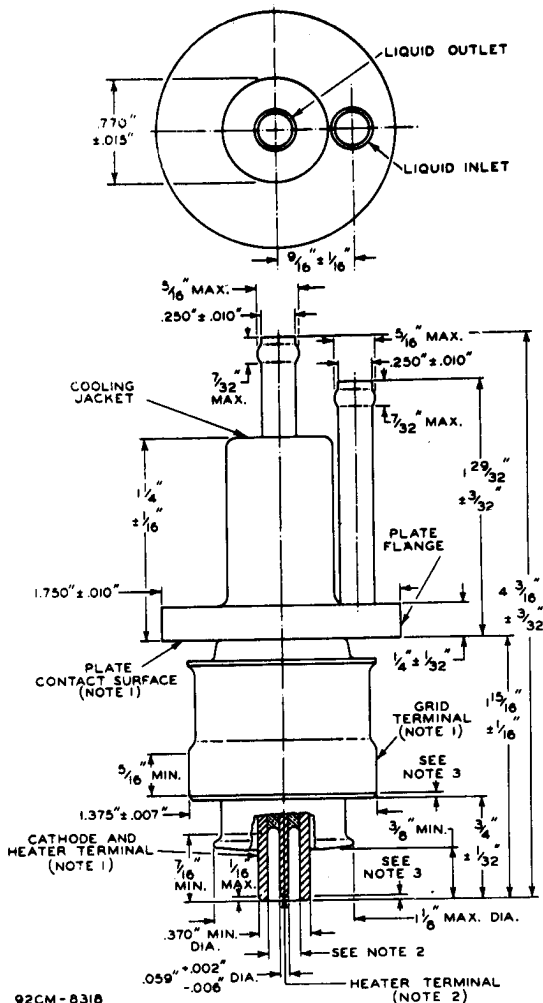

92CM-8318

AUG. 16, 1954

TUBE DIVISION

RADIO CORPORATION OF AMERICA, HARRISON, NEW JERSEY

CE-8318A



6383

6383

POWER TRIODE

NOTE 1: WITH THE CYLINDRICAL SURFACES OF ITS GRID AND CATHODE TERMINALS CLEAN, SMOOTH, AND FREE OF BURRS, THE TUBE WILL ENTER A GAUGE AS SHOWN IN SKETCH G_1 . THE FOUR CYLINDRICAL HOLES H_1 , H_2 , H_3 , and H_4 HAVE AXES COINCIDENT WITHIN 0.0005", LENGTHS DETERMINED FROM THE DIMENSIONAL OUTLINE, AND SUCCESSIVELY SMALLER DIAMETERS AS SHOWN IN THE SKETCH.

THE PLATE FLANGE WILL BE ENTIRELY ENGAGED BY HOLE H_1 , AND CONTACT SURFACE OF THE PLATE FLANGE WILL SEAT ON THE SHOULDER BETWEEN HOLES H_1 AND H_2 . THE PLANE SURFACE OF THIS SHOULDER IS $90^\circ \pm 2'$ TO THE AXES OF THE HOLES. SEATING IS DETERMINED BY FAILURE OF A 0.005" THICKNESS GAUGE, 1/8" WIDE, TO ENTER MORE THAN 1/16" BETWEEN THIS SHOULDER SURFACE AND THE PLATE CONTACT SURFACE.

WITH THE TUBE PROPERLY SEATED AS DESCRIBED ABOVE, THE GRID TERMINAL WILL BE ENTIRELY ENGAGED BY HOLE H_3 , AND THE CATHODE TERMINAL WILL BE ENGAGED BY HOLE H_4 TO A DEPTH OF AT LEAST 1/4".

NOTE 2: CONCENTRICITY OF THE HEATER TERMINAL WITH RESPECT TO THE CATHODE TERMINAL IS DETERMINED BY A GAUGE AS SHOWN IN SKETCH G_2 . THE CYLINDRICAL HOLE H_5 AND THE ANNULAR HOLE H_6 HAVE AXES COINCIDENT WITHIN 0.0005". THE CATHODE TERMINAL AND THE HEATER TERMINAL WILL ENTER THIS GAUGE TO A DEPTH OF 3/8".

NOTE 3: MAY BE ROUNDED OR BEVELED NOT TO EXCEED 1/16".

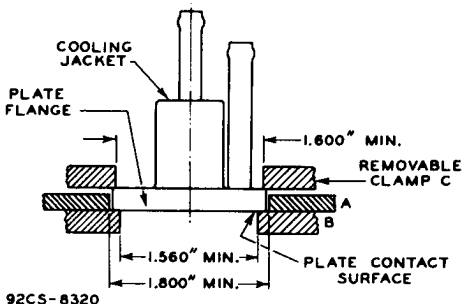
Mounting Arrangement for Use with
Coaxial-Line or Cavity Circuits

6383



6383

POWER TRIODE

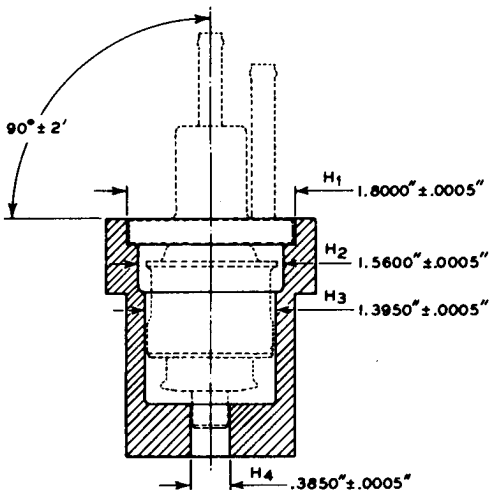
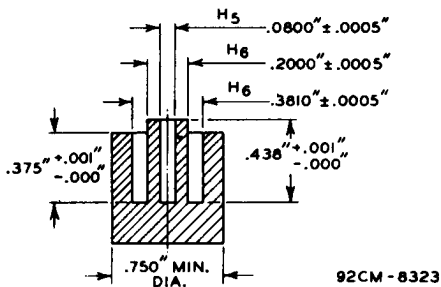
Sketch G₁Sketch G₂



6383

6383

AVERAGE CHARACTERISTICS

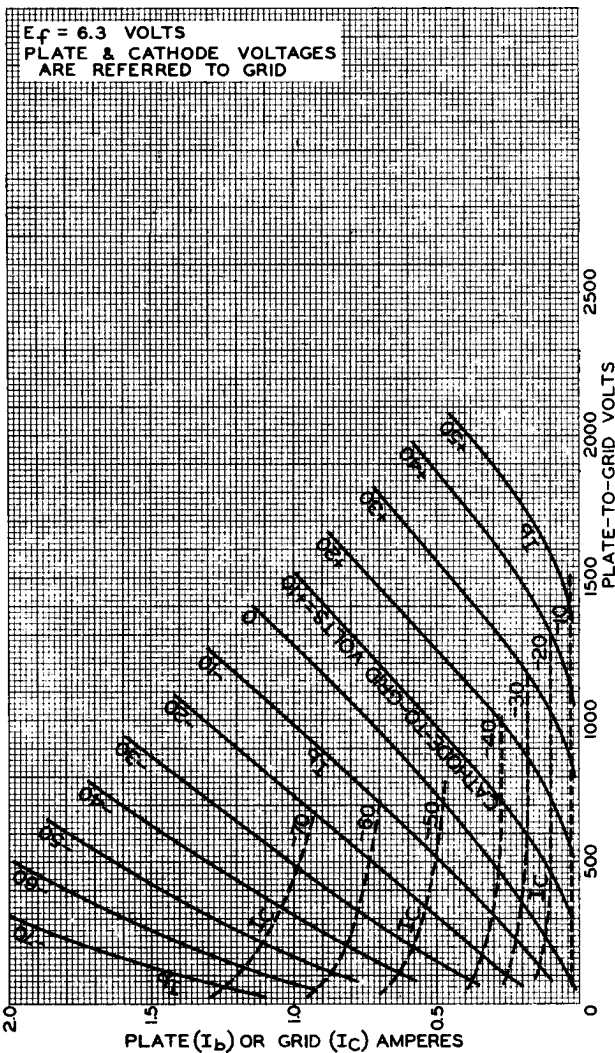

APRIL 26, 1954

TUBE DIVISION

92CL-7771R1

RADIO CORPORATION OF AMERICA, HARRISON, NEW JERSEY