



7086

7086

# XENON THYRATRON

NEGATIVE-CONTROL TRIODE TYPE

FORCED-AIR COOLED

## GENERAL DATA

### Electrical:

Filament, Coated:*		
Voltage . . . . .	2.5 ± 5%	ac volts
Current at 2.5 volts . . . . .	92	amp
Minimum heating time, prior to tube conduction. . . . .	60	sec
Direct Interelectrode Capacitances: <sup>o</sup>		
Grid to anode . . . . .	44	μf
Grid to filament . . . . .	7.5	μf
Ionization Time (Approx.) . . . . .	10	μsec
Deionization Time* . . . . .	1000	μsec
Maximum Critical Grid Current for instantaneous anode volts = 650 . . . . .	50	μa
Peak Tube Voltage Drop . . . . .	<i>See Characteristics Range Values</i>	
Maximum Commutation Factor <sup>⊕</sup> . . . . .	400	va/μsec <sup>2</sup>

### Grid Control Ratio (Approx.):

Under conditions: 10000-ohm grid resistor, returns to filament terminal FS, voltage on filament terminal F in phase with anode voltage (with respect to voltage at FS), anode voltage between 100 and 700 volts, and plate load of 2000 ohms . . . . . 100

### Mechanical:

Operating Position . . . . .	Any
Maximum Overall Length . . . . .	11.8"
Maximum Radius (Including grid terminal) . . . . .	2.88"
Maximum Diameter (Excluding grid terminal) . . . . .	4.62"
Weight (Approx.) . . . . .	3 lbs
Bulb . . . . .	T36
Terminal Connections ( <i>See Dimensional Outline</i> ):	

P - Anode

G - Grid

F - Filament

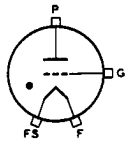

FS - Filament Cathode Shield Circuit Returns

Air Flow . . . . . 60 cfm

The specified air flow, from a 2- to 3-inch diameter nozzle located about 12 inches from the anode end of the tube and on the tube axis, should be directed at the anode cup and permitted to flow freely around the outside of the anode cup, grid-seal band, and glass bulb. These requirements are for operation at sea level and at an ambient temperature of

\* , <sup>o</sup> , \* , <sup>⊕</sup> : See next page.



# XENON THYRATRON

30° C. At higher altitudes and ambient temperatures, the air flow must be increased to maintain the respective seal temperatures and the anode temperature within maximum ratings.

Anode Temperature (Measured within 1/2 inch of region where anode terminal blade joins anode surface) . . . . .	300 max.	°C
Temperature of Anode Seal, Grid Seals, and Filament Seals. . . . .	180 max.	°C

### Maximum Ratings, Absolute Values:

*For supply frequency of 25 to 60 cps*

	Continuous Service <sup>■</sup>	Intermittent Service <sup>♣</sup>	
<b>PEAK ANODE VOLTAGE:</b>			
Forward . . . . .	650 max.	650 max.	volts
Inverse . . . . .	650 max.	650 max.	volts
<b>GRID VOLTAGE:</b>			
Peak, before tube conduction . . . . .	-150 max.	-150 max.	volts
Average, during tube conduction . . . . .	-10 max.	-10 max.	volts
<b>ANODE CURRENT:</b>			
Peak . . . . .	160 max.	400 max.	amp
Average . . . . .	40 max. <sup>●□</sup>	7 max. <sup>★□</sup>	amp
Fault, for duration of 0.1 second maximum . . . . .	4000 max.	4000 max.	amp
<b>GRID CURRENT:</b>			
Average positive . . . . .	2.0 max.	2.0 max.	amp
Peak positive with anode negative . . . . .	0.1 max.	0.1 max.	amp
<b>AMBIENT-TEMPERATURE RANGE . . . . .</b>			
	-55 to +75	-55 to +75	°C

### Typical Operation:

*For intermittent ac control of X-ray tube power utilizing inverse-parallel circuit of Fig. 1 with anode-supply frequency of 60 cps*

"On" (Conduction) Period . . . . .	2	sec
"Off" (Non-Conduction) Period . . . . .	34	sec
RMS Anode-Supply Voltage . . . . .	220	volts
Grid-Bias Voltage . . . . .	-50	volts
Grid-Circuit Resistance . . . . .	0.1	megohm
Grid-Pulse Voltage . . . . .	60	volts
<b>Anode Current (Per Tube):</b>		
Peak . . . . .	400	amp
Average <sup>▲</sup> . . . . .	127	amp
Load RMS Demand Current . . . . .	280	amp

\* , ◊ , # , ⊕ , ♣ , ● , □ , ★ , ▲ : See next page.



7086

7086

## XENON THYRATRON

## Maximum Circuit Values:

	Continuous Service	Intermittent Service	
Grid-Circuit Resistance. . .	0.1 max.	0.1 max.	megohm

## CHARACTERISTICS RANGE VALUES FOR EQUIPMENT DESIGN

## Throughout Tube Life

	Note	Min.	Max.	
Filament Current . . . . .	1	87	97	amp
Peak Tube Voltage Drop . . . . .	1,2	-	40	volts
Peak Critical Anode Voltage. . . . .	1,3	-	100	volts

Note 1: With 2.5 volts rms on filament.

Note 2: With peak anode current of 400 amperes provided by a half-cycle pulse from a 60-cps sine wave. Pulse recurs once each second. Tube drop is measured by an oscilloscope connected between anode and the filament terminal FS. The grid is tied to anode through a 10,000-ohm resistor.

Note 3: The voltage at terminal F is in phase with the anode voltage (with respect to voltage at filament terminal FS). Circuit returns are made to terminal FS. Grid resistor = 0 to 100,000 ohms.

\* In single-phase applications, to avoid excessive heating of the filament and for maximum tube life, the voltage at filament terminal F should be in phase with the voltage at the anode terminal (with respect to voltage at filament terminal FS). All returns should be made to filament terminal FS in order to reduce the amount of rms current flowing through the filament and filament leads. In polyphase installations, quadrature operation of the filament is recommended to reduce excessive heating of the filament and filament leads by the anode-return current. In quadrature operation, the filament and anode voltages should be 90° out of phase for optimum results. However, in practical applications, nearly full realization of the advantages of this type of excitation is possible with the filament and anode voltages between 60° and 120° out of phase. In polyphase operation where the anode voltage transfers from one phase to another during the current-conduction period, quadrature operation is obtained when the filament voltage passes through zero at the center of the current-conduction period.

○ Without external shield.

\* Measured by Capacitor-Discharge Method as described in "Standard on Electron Tubes: Methods of Testing, 1950 (50 IRE 7.52)" available from The Institute of Radio Engineers, 1 East 79 St., New York 21, N. Y. Also available in "Proceedings of the I.R.E.", Vol.38, No.9, page 1092 (September 1950). Conditions of measurement involve anode-supply voltage (E<sub>bb</sub>) of 300 volts, grid-supply voltage (E<sub>cc</sub>) of -150 volts, grid resistor (r<sub>g</sub>) of 5000 ohms and anode current (I<sub>b</sub>) of 23 amperes.

⊕ Commutation factor is the product of the rate of current decay in amperes per microsecond just before conduction ceases and the rate of inverse-voltage rise in volts per microsecond following current conduction.

● Continuous Service is defined as service where conduction recurs for each cycle of the anode-supply voltage.

⊙ Intermittent Service is defined as service where conduction does not take place as often as every cycle of the anode-supply voltage.

● Averaged over any period of 15 seconds maximum.

□ This rating applies when the average or the rms load current is at a maximum with respect to the phase-retard angle. This condition obtains with zero phase-retard angle. As the phase-retard angle is increased, the average or rms load current is reduced but the severity of duty on the 7086 is not reduced.

\* , ▲ : See next page.



## XENON THYRATRON

The angle of phase retard is the angle by which the grid signal (or the resultant tube conduction) lags the time at which the incoming and outgoing tubes have equal instantaneous values of voltage from the sinusoidal supply.

★ Averaged over any period of 36 seconds maximum.

▲ Averaged over the "on" period of 2 seconds.

### OPERATING CONSIDERATIONS

The *mounting* may support the 7086 in any position. A suitable mounting arrangement is provided by the use of three insulated 1/4-inch-diameter studs set perpendicularly in a rigid surface at locations which are spaced to correspond with the spacing of the terminal holes as shown on the Dimensional Outline. The studs should extend a minimum distance of 5 inches out from the surface, and should be threaded for a minimum length of 2 inches on their free end. Place a nut followed by a brass or copper washer on each stud so that 1-1/2 inches of the free end extends beyond the washer. Then mount the tube by slipping the holes of the tube's terminals onto the studs. The terminal lugs of the connecting leads to the tube can then be slipped onto their respective studs. Tighten the connection with a second nut on each stud. *In order not to subject the glass-to-metal seals to stress which may damage them, use two wrenches--one on each side of the tube terminals when tightening a connection.*

Filament leads should be made of No.2 stranded copper wire, or equivalent. The tube end of the wire lead should be hard soldered to a 225-ampere (minimum) copper terminal lug. Be sure that this terminal lug is placed in direct contact with the filament terminal before tightening the nut.

The anode lead should be made of No.5 copper wire, or equivalent, and terminate at the tube end in a 150-ampere (minimum) copper terminal lug.

The grid lead should terminate at the tube end in a lug that may be fastened to the grid terminal by a No.6 screw & nut.

*Sufficient anode-circuit resistance, including the tube load, must be used under any conditions of operation to prevent exceeding the current ratings of the tube.*



7086

7086

# XENON THYRATRON

## Numerical Relationships Among Electrical Quantities

- |  |  |
|--|--|
| E = Trans. Sec. Voltage (RMS)          | $I_1$ = RMS Load Current                       |
| $E_{av}$ = Average DC Output Voltage   | $I_p$ = Anode Current (RMS)                    |
| $E_{bmf}$ = Peak Forward Anode Voltage | $I_{pm}$ = Peak Anode Current                  |
| $E_{bmi}$ = Peak Inverse Anode Voltage | $P_{ac}$ = Average Power in Load               |
| $E_m$ = Peak DC output Voltage         | $P_{al}$ = Line Volt-Amperes                   |
| $E_r$ = Major Ripple Voltage (RMS)     | $P_{ap}$ = Trans. Pri. Volt-Amperes            |
| f = Supply Frequency                   | $P_{as}$ = Trans. Sec. Volt-Amperes            |
| $f_r$ = Major Ripple Frequency         | $P_{dc}$ = DC Power ( $E_{av} \times I_{av}$ ) |
| $I_{av}$ = Average DC Output Current   | $P_p$ = Peak Load Volt-Amperes                 |
| $I_b$ = Average Anode Current          |  |

*Note: Conditions assumed involve sine-wave supply; zero voltage drop in tubes; no losses in transformer and circuit; no back emf in the load circuit; and no phase-back.*

RATIO	Fig. 1	Fig. 2	Fig. 3	Fig. 4	Fig. 5
<b>Voltage Ratios</b>					
$E/E_{av}$	-	-	2.22	1.11	1.11
$E_{bmi}/E$	1.41	1.41	1.41	2.83	1.41
$E_{bmi}/E_{av}$	-	-	3.14	3.14	1.57
$E_m/E_{av}$	-	-	3.14	1.57	1.57
$E_r/E_{av}$	-	-	1.11	0.472	0.472
$E_{bmf}/E$ :					
Resistive Load	1.41	1.41	1.41	1.41	1.41
Inductive Load <sup>■</sup>	1.41	1.41	1.41	2.83	1.41
<b>Frequency Ratio</b>					
$f_r/f$	-	-	1	2	2
<b>Current Ratios</b>					
$I_b/I_{av}$	-	-	1	0.5	0.5
Resistive Load					
$I_p/I_{av}$	-	-	1.57	0.785	0.785
$I_{pm}/I_{av}$	-	-	3.14	1.57	1.57
$I_{pm}/I_b$	3.14	3.14	3.14	3.14	3.14
$I_1/I_b$	2.22	2.22k*	-	-	-
Inductive Load <sup>■</sup>					
$I_p/I_{av}$	-	-	-	0.707	0.707
$I_{pm}/I_{av}$	-	-	-	1	1
$I_{pm}/I_b$	-	-	-	2	2
$I_b/I_{av}$	-	-	-	0.5	0.5

■, \* : See next page.



## XENON THYRATRON

RATIO	Fig.1	Fig.2	Fig.3	Fig.4	Fig.5
<b>Power Ratios</b>					
$P_{ac}/I_b E_{bmf}$	1.57	1.57	-	-	-
<i>Resistive Load</i>					
$P_{as}/P_{dc}$	-	-	3.49	1.74	1.24
$P_{ap}/P_{dc}$	-	-	2.69	1.23	1.24
$P_{a1}/P_{dc}$	-	-	2.69	1.23	1.24
<i>Inductive Load</i> <sup>■</sup>					
$P_{as}/P_{dc}$	-	-	-	1.57	1.11
$P_{ap}/P_{dc}$	-	-	-	1.11	1.11
$P_{a1}/P_{dc}$	-	-	-	1.11	1.11

■ The use of a large filter-input choke is assumed except for the circuit of Figs.1 and 2.

\*  $k = 1/2$  number of turns in secondary of transformer  $T_p$  divided by the number of turns in the primary of  $T_p$ .

CIRCUIT Single-Phase	MAX. TRANS. SEC. VOLTS (RMS) E	APPROX. DC OUTPUT VOLTS TO FILTER $E_{av}$	MAX. DC OUTPUT AMPERES $I_{av}$	MAX. DC OUTPUT KW TO FILTER $P_{dc}$	MAX. AV. AC OUTPUT KVA $P_{ac}$
<b>Fig.1</b> Inverse-Parallel (AC Voltage Control)					
<i>Intermittent Service</i>	460	-	-	-	$\left\{ \begin{array}{l} 130\blacktriangle \\ 7\blacklozenge \\ 40\blacktriangledown \end{array} \right.$
<i>Continuous Service</i>	460	-	-	-	
<b>Fig.2</b> Full-Wave Reflected Impedance (AC Voltage Control)	460	-	-	-	40 $\blacktriangledown$
<b>Fig.3</b> Half-Wave (DC Voltage Control)	460	205	40	8	-
<b>Fig.4</b> Full-Wave (DC Voltage Control)					
<i>With Resistive Load</i>	230	205	80	16	-
<i>With Inductive Load</i>	230	205	80	16	-
<b>Fig.5</b> Series (DC Voltage Control)	460	410	80	32.5	-

▲ Under conditions with "on" period of 2 seconds and "off" period of 34 seconds.

◆ Averaged over any period of 36 seconds maximum.

♣ Averaged over any period of 15 seconds maximum.



7086

7086

## OPERATIONAL RANGE OF CRITICAL GRID VOLTAGE

RANGE IS FOR CONDITIONS WHERE:  
 $E_f = 2.5$  VOLTS AC  $\pm 5\%$ . CIRCUIT RETURNS TO FILAMENT TERMINAL FS. FILAMENT VOLTAGE AT TERMINAL F IN PHASE WITH ANODE VOLTAGE (WITH RESPECT TO VOLTAGE AT FS). THE RANGE INCLUDES INITIAL AND LIFE VARIATIONS OF INDIVIDUAL TUBES.  
 GRID RESISTOR = 0 TO 100000 OHMS  
 AMBIENT-TEMPERATURE RANGE =  $-55^\circ$  TO  $+75^\circ$  C

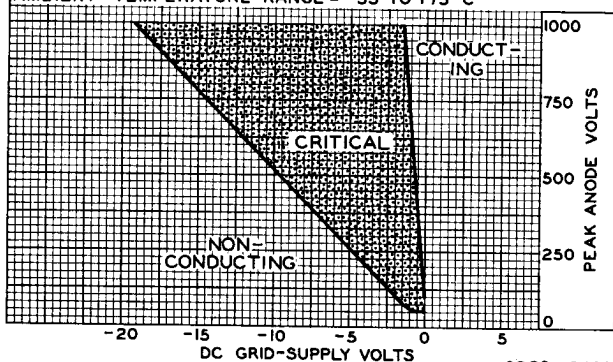

92CS-9436

## SHIFT OF TYPICAL CONTROL CHARACTERISTICS WITH CHANGE IN FILAMENT PHASING AND CIRCUIT RETURN

$E_f = 2.5$  VOLTS AC  
 GRID RESISTOR = 10000 OHMS  
 \* BETWEEN FILAMENT VOLTAGE AT TERMINAL F AND ANODE VOLTAGE (WITH RESPECT TO VOLTAGE AT FS).

CURVE	PHASE ANGLE *	CIRCUIT RETURN TO FIL. TERM.
A	$0^\circ$	FS
B	$180^\circ$	F
C	$0^\circ$	F
D	$180^\circ$	FS

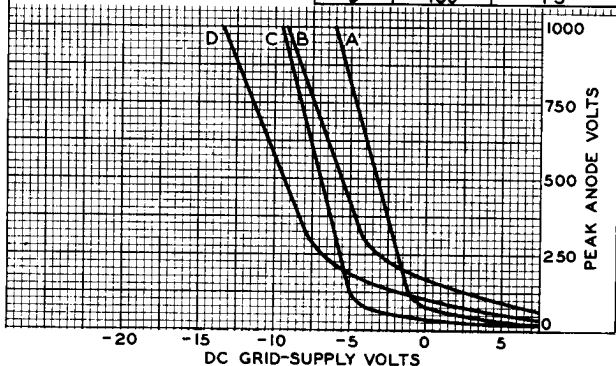

ELECTRON TUBE DIVISION

RADIO CORPORATION OF AMERICA, HARRISON, NEW JERSEY

92CS-9426

7086



7086

## XENON THYRATRON

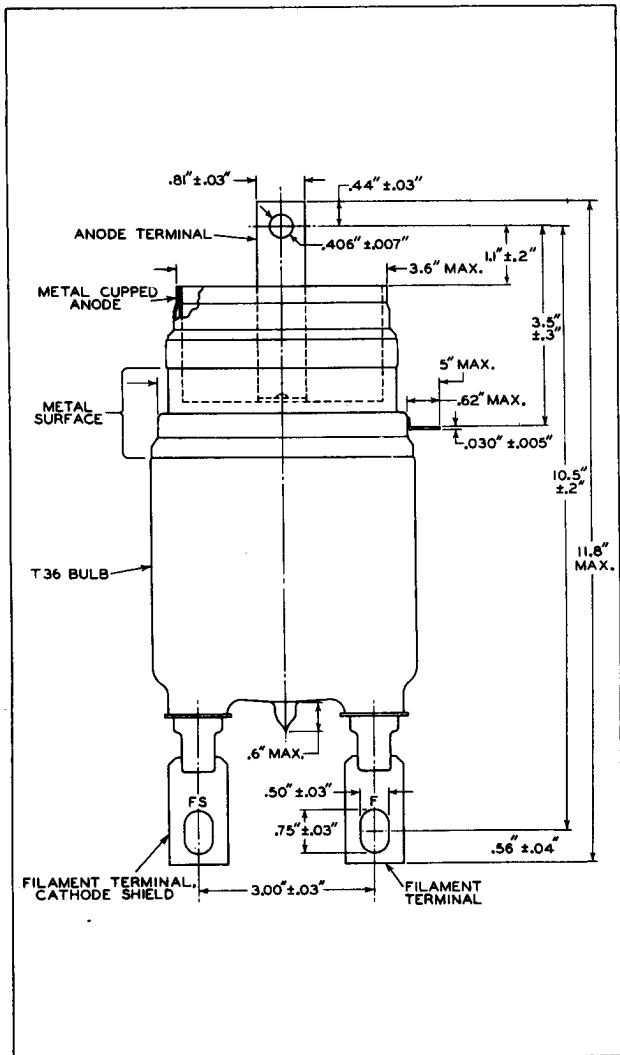





7086

7086

# XENON THYRATRON

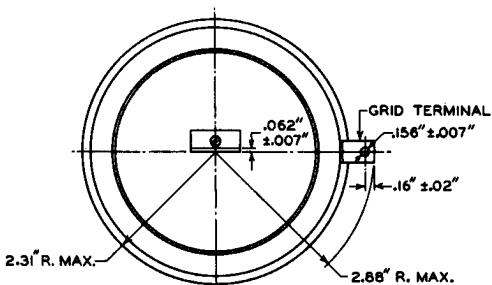

TOP VIEW

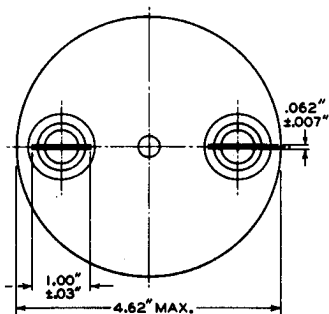

BOTTOM VIEW

92CJ-9424

7086



7086

### SHIFT OF CONTROL CHARACTERISTICS WITH CHANGE IN GRID-RESISTOR VALUE

* BETWEEN FILAMENT VOLTAGE AT TERMINAL F AND ANODE VOLTAGE (WITH RESPECT TO VOLTAGE AT FS).	CURVE	GRID RESISTOR MEGOHMS	CIRCUIT RETURN TO FIL. TERM.	PHASE ANGLE *
				0
	A	0.01	FS	0
	B	0.1	FS	0
	C	1	FS	0

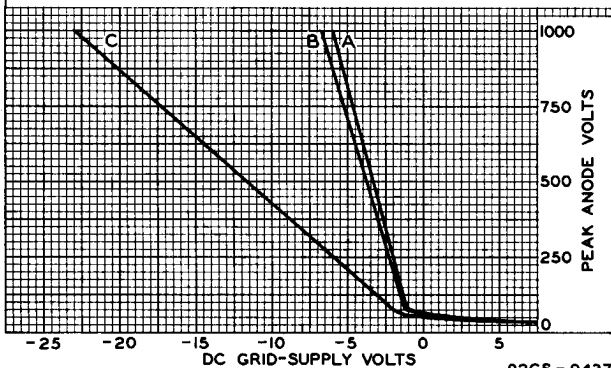

92CS-9437

### TYPICAL GRID CHARACTERISTICS DURING TUBE CONDUCTION

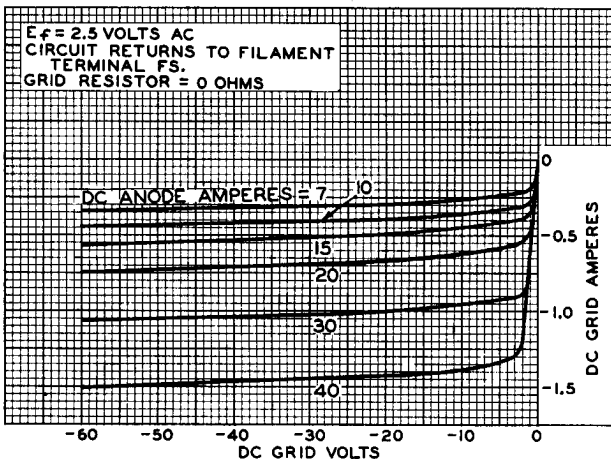

92CS-9425



7086

7086

### CURRENT DEMAND CHARACTERISTIC AC VOLTAGE CONTROL SERVICE

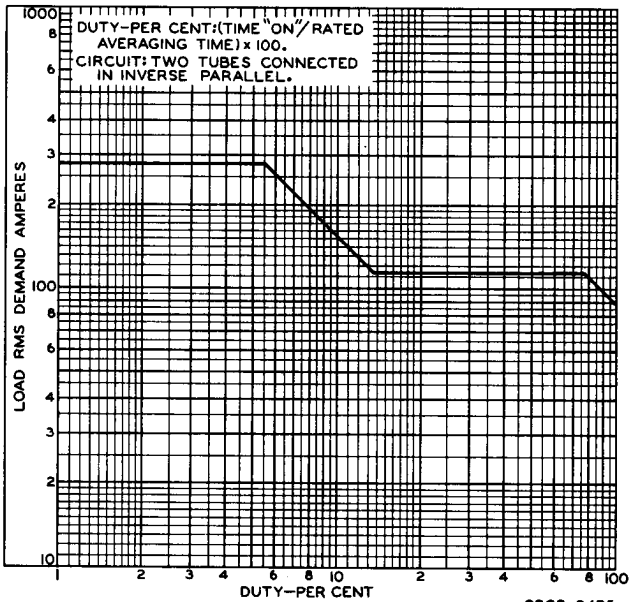

92CS-9435



7086

7086

# XENON THYRATRON

## AC Voltage Control

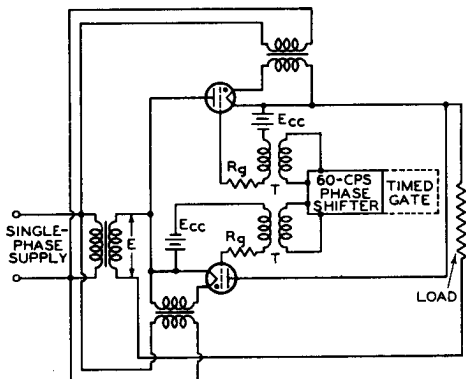

FIG. 1 SINGLE-PHASE INVERSE-PARALLEL

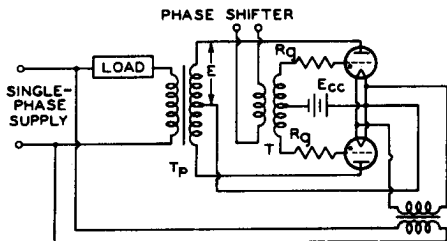

FIG. 2 FULL-WAVE SINGLE-PHASE REFLECTED IMPEDANCE

Devices and arrangements shown or described herein may use patents of RCA or others. Information contained herein is furnished without responsibility by RCA for its use and without prejudice to RCA's patent rights.



7086

## XENON THYRATRON

## DC Voltage Control

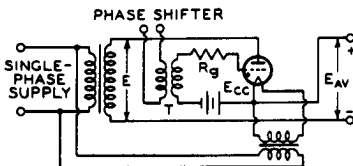

FIG. 3 HALF-WAVE SINGLE-PHASE

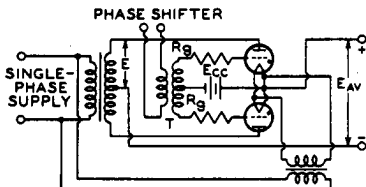

FIG. 4 FULL-WAVE SINGLE-PHASE

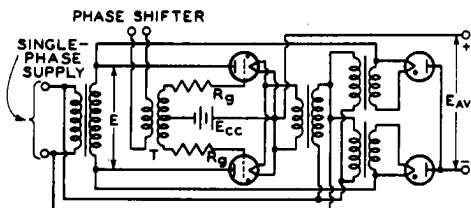

FIG. 5 SERIES SINGLE-PHASE

## NOTES

E<sub>cc</sub> = GRID-BIAS SUPPLY VOLTAGER<sub>g</sub> = GRID CIRCUIT RESISTANCE

T = PEAKING TRANSFORMER

IN FIG. 5, THE RECTIFIER TUBES  
MAY BE USED AS DIODES.THE 7086 IS USED AS A  
DIODE BY CONNECTING THE  
GRID TO FILAMENT TERMINAL  
FS.

92CL-9438