

Image Orthicon

MAGNETIC FOCUS

MAGNETIC DEFLECTION

EXCELLENT RESOLUTION CAPABILITY

For Outdoor and Studio Pickup with High-Quality Black-and-White TV Cameras. The 7295B is Unilaterally Interchangeable with Types 7295 and 7295A.

DATA

General:

Heater, for Unipotential Cathode:

Voltage (AC or DC)	6.3 ± 10%	volts
Current at 6.3 volts	0.6	amp

Direct Interelectrode Capacitance:

Anode to all other electrodes	12	pf
---	----	----

Target-to-Mesh Spacing	0.002	inch
----------------------------------	-------	------

Spectral Response	S-10	
-----------------------------	------	--

Wavelength of Maximum Response	4500 ± 300	angstroms
--	------------	-----------

Photocathode, Semitransparent:

Rectangular image (4 x 3 aspect ratio):

Useful size	1.6" max.	diagonal
-----------------------	-----------	----------

Note: The size of the optical image focused on the photocathode should be adjusted so that its maximum diagonal does not exceed the specified value. The corresponding electron image on the target should have a size such that the corners of the rectangle just touch the target ring.

Orientation Proper orientation is obtained when the vertical scan is essentially parallel to the plane passing through center of the faceplate and the grid-No.6 envelope terminal. The horizontal and vertical scan should start at the corner of the picture between the grid-No.6 and the photocathode envelope terminals.

Focusing Method	Magnetic
---------------------------	----------

Deflection Method	Magnetic
-----------------------------	----------

Overall Length	19.375" ± 0.310"
--------------------------	------------------

Greatest Diameter of Bulb	4.500" ± 0.094"
-------------------------------------	-----------------

Minimum Deflecting-Coil Inside Diameter	3.2"
---	------

Deflecting-Coil Length	7"
----------------------------------	----

Focusing-Coil Length	15"
--------------------------------	-----

Alignment-Coil:

Position on neck . . . Centerline of magnetic field should be located 9.25" from the flat area of the shoulder.

Operating Position See *Operating Considerations*

Weight (Approx.)	2.3 lbs
----------------------------	---------

Socket	Cinch [▲] Part No. 3M14, or equivalent
------------------	---

Envelope Terminals	5
------------------------------	---

BOTTOM VIEW[▲]

Terminal Over Pin 2 - Field Mesh

Terminal Over Pin 4 - Photocathode (PC)

Terminal On Side of Envelope

Opposite Base Key - Grid No.6 (G₆)

[▲] See basing diagram on next page.



7295B

Terminal Over Pin 9 - Grid No.5 (G₅)

Terminal Over Pin 11 - Target

End Base Small-Shell Diheptal 14-Pin
(JEDEC Group 5, No. B14-45)

BOTTOM VIEW

- Pin 1 - Heater
- Pin 2 - Grid No.4
- Pin 3 - Grid No.3
- Pin 4 - Do Not Use
- Pin 5 - Dynode No.2
- Pin 6 - Dynode No.4
- Pin 7 - Anode
- Pin 8 - Dynode No.5
- Pin 9 - Dynode No.3
- Pin 10 - Dynode No.1,
Grid No.2
- Pin 11 - Do Not Use
- Pin 12 - Grid No.1
- Pin 13 - Cathode
- Pin 14 - Heater

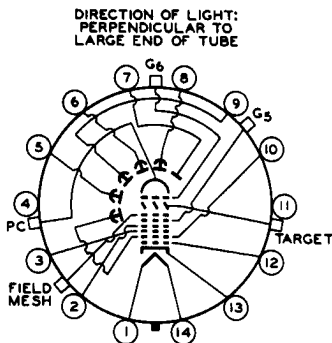

Maximum and Minimum Ratings, Absolute-Maximum Values:

PHOTOCATHODE:

Voltage	-700 max.	volts
Illumination	50 max.	fc

OPERATING TEMPERATURE:^b

Any part of bulb	65 max.	°C
Of bulb at large end of tube (Image section)	35 min.	°C

TEMPERATURE DIFFERENCE:

Between image section and any part of bulb hotter than image section . .	5 max.	°C
---	--------	----

GRID-No.6 VOLTAGE	-700 max.	volts
-----------------------------	-----------	-------

TARGET VOLTAGE:

Positive value	10 max.	volts
Negative value	10 max.	volts

FIELD-MESH VOLTAGE ^c	30 max.	volts
---	---------	-------

GRID-No.5 VOLTAGE	300 max.	volts
-----------------------------	----------	-------

GRID-No.4 VOLTAGE	350 max.	volts
-----------------------------	----------	-------

GRID-No.3 VOLTAGE	400 max.	volts
-----------------------------	----------	-------

GRID-No.2 & DYNODE-No.1 VOLTAGE	350 max.	volts
---	----------	-------

GRID-No.1 VOLTAGE:

Negative-bias value	125 max.	volts
Positive-bias value	0 max.	volts

VOLTAGE PER MULTIPLIER STAGE	350 max.	volts
--	----------	-------

ANODE SUPPLY VOLTAGE ^d	1650 max.	volts
---	-----------	-------

PEAK HEATER-CATHODE VOLTAGE:

Heater negative with respect to cathode .	125 max.	volts
Heater positive with respect to cathode .	10 max.	volts



Typical Operating Values:^e

Photocathode Voltage	-600	volts
Grid-No.6 Voltage (Image Focus) Approx. 50% of photocathode voltage ^f	-250 to -350	volts
Target Voltage Above Cutoff ^g	2.3	volts
Field-Mesh Voltage ^c	15 to 25	volts
Grid-No.5 Voltage (Decelerator)	40	volts
Grid-No.4 Voltage (Beam Focus)	70 to 90	volts
Grid-No.3 Voltage ^h	250 to 275	volts
Grid-No.2 & Dynode-No.1 Voltage	280	volts
Grid-No.1 Voltage for picture cutoff	-45 to -115	volts
Dynode-No.2 Voltage	600	volts
Dynode-No.3 Voltage	800	volts
Dynode-No.4 Voltage	1000	volts
Dynode-No.5 Voltage	1200	volts
Anode Voltage	1250	volts
Recommended Target-Temperature Range ^b	35 to 45	°C
Minimum Peak-to-Peak Blanking Voltage	5	volts
Field Strength of Focusing Coil (Approx.): ^j		
At center of scanning section	60	gausses
In plane of photocathode	120	gausses
Field Strength of Alignment Coil	0 to 3	gausses

Performance Data:

With conditions shown under Typical Operating Values including Recommended Target-Temperature Range, target voltage adjusted to 2.3 volts above cutoff, and with the camera lens set to bring picture highlights one stop above the "knee" of the accompanying Basic Light-Transfer-Characteristic Curve

	Min.	Average	Max.	
Cathode Radiant Sensitivity at 4500 angstroms	-	0.030	-	a/w
Luminous Sensitivity	30	60	-	μa/lm
Signal-Output Current (Peak to Peak)	10	-	40	μa
Ratio of Peak-to-Peak High- light Video Signal Current to RMS Noise Current for Bandwidth of 4.5 Mc	60.1	75.1	-	
Photocathode Illumination at 2870° K Required to bring Picture Highlights One Stop above "Knee" of Light-Transfer Characteristic	-	-	0.110	fc
Amplitude Response at 400 TV Lines per Picture Height (Per cent of large-area black to large-area white) ^k	60	75	-	%
Uniformity: ^m				
Ratio of Shading (Back- ground) Signal to Highlight Signal	-	0.10	0.15	



7295B

	<i>Min.</i>	<i>Average</i>	<i>Max.</i>	
Decrease from Peak Highlight Signal Level of Signal from any Point on Scanned Area of Target. .	-	12	25	%

- ^a Cinch Manufacturing Corporation, 1026 South Homan Avenue, Chicago 24, Illinois.
- ^b Operating outside the *Recommended Target-Temperature Range* shown under *Typical Operating Values* will not damage the 7295B provided the *Maximum Temperature Ratings* of the tube are not exceeded. Optimum performance, however, is only obtained when the tube is operated within the *Recommended Target-Temperature Range*.
- ^c With respect to grid No.4.
- ^d Dynode-voltage values are shown under *Typical Operating Values*.
- ^e With 7295B operated in RCA TK-60 camera at fixed photocathode voltage.
- ^f Adjust for optimum focus.
- ^g The target supply voltage should be adjustable from -5 to 5 volts.
- ^h Adjust to give the most uniformly shaded picture near maximum signal.
- ^j Direction of current should be such that a north-seeking pole is attracted to the image end of the focusing coil, with the indicator located outside of and at the image end of the focusing coil.
- ^k Measured with amplifier having flat frequency response.
- ^m With uniform illumination on photocathode.

OPERATING CONSIDERATIONS

The tube should never be operated in a vertical position with the Diheptal/base end up nor in any other position where the axis of the tube with base up makes an angle of less than 20° with the vertical.

**SPECTRAL-SENSITIVITY CHARACTERISTIC
of Photosensitive Device having S-10 Response
is shown at the front of this Section**



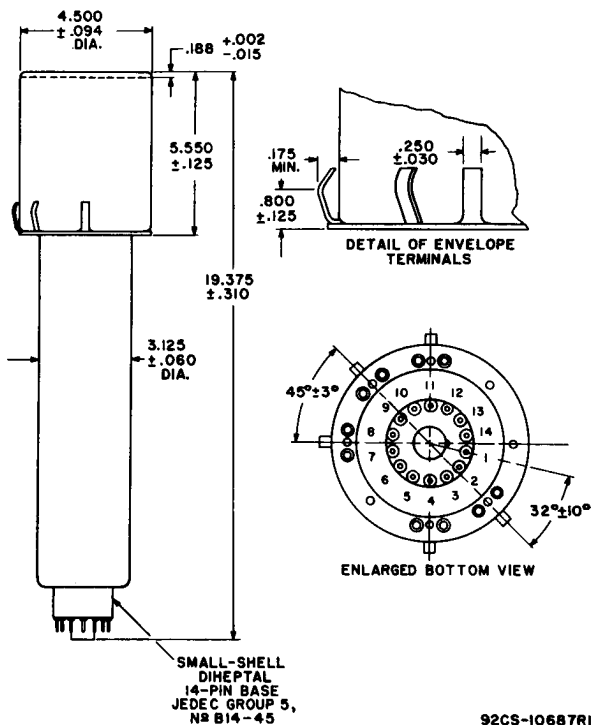

ALL DIMENSIONS IN INCHES



BASIC LIGHT-TRANSFER CHARACTERISTIC

