

HYDROGEN
THYRATRON

Service Type CV6022

The data to be read in conjunction with the Hydrogen Thyatron Preamble.

ABRIDGED DATA

Hydrogen-filled triode thyatron, positive grid, for pulse operation. A hydrogen reservoir is incorporated. Electrically superior to 5C22 and ruggedized to meet the requirements of airborne applications. Environmental tests applied to the tube include linear acceleration at 12g, and vibration at ¼g minimum acceleration and 150Hz frequency or at the frequency of maximum resonance in the range between 10 and 150Hz.

| | | |
|--------------------------------------|-------------------|----------------|
| Peak forward anode voltage | 16 | kV max |
| Peak anode current | 325 | A max |
| Average anode current | 250 | mA max |
| Anode heating factor | 3.9×10^9 | V.A.p.p.s. max |
| Peak output power | 2.6 | MW max |

GENERAL

Electrical

| | |
|---|--------------|
| Cathode (connected internally to one end of heater) | oxide coated |
| Heater voltage | 6.3 + 7.5% V |
| Heater current | 10.6 A |
| Tube heating time (minimum) | 3.0 min |

Mechanical

| | |
|-----------------------------|----------------------------|
| Overall length | 8.750 inches (222.3mm) max |
| Overall diameter | 2.563 inches (65.1mm) max |
| Net weight | 12 ounces (350g) approx |
| Mounting position | any |
| Clamping | see note 1 |
| Base | B4D, bayonet |
| Top cap | B.S.448-CT3 |

| | |
|-------------------|---------|
| Cooling | natural |
|-------------------|---------|

PULSE MODULATOR SERVICE

MAXIMUM AND MINIMUM RATINGS (Absolute values)

| | Min | Max | |
|---|--------------------------|-------------------|--------------|
| Anode | | | |
| Peak forward anode voltage (see note 2) | — | 16 | kV |
| Peak inverse anode voltage (see note 3) | — | 16 | kV |
| Peak anode current | — | 325 | A |
| Average anode current | — | 250 | mA |
| Rate of rise of anode current (see note 4) | — | 1500 | A/ μ s |
| Anode heating factor | — | 3.9×10^9 | V.A.p.p.s. |
| Grid | | | |
| Unloaded grid drive pulse voltage (see note 5) | 200 | — | V |
| Grid pulse duration | 2.0 | — | μ s |
| Rate of rise of grid pulse (see note 4) | 180 | — | V/ μ s |
| Peak inverse grid voltage | — | 200 | V |
| Loaded grid bias voltage | 0 | -120 | V |
| Forward impedance of grid drive circuit | 50 | 500 | Ω |
| Cathode | | | |
| Heater voltage | $6.3 \pm 7\frac{1}{2}\%$ | | V |
| Tube heating time | 3.0 | — | min |
| Environmental | | | |
| Environmental performance | | | see note 6 |
| Ambient temperature | -50 | +90 | $^{\circ}$ C |
| Altitude | — | 10 000 | ft |
| | — | 3 | km |

CHARACTERISTICS

| | Min | Typical | Max | |
|--|------------------------|---------|------|-------------|
| Critical d.c. anode voltage for conduction (see note 7) | — | 0.3 | 1.0 | kV |
| Anode delay time (see notes 7 and 8) | — | 0.3 | 0.65 | μ s |
| Anode delay time drift (see notes 7 and 9) | — | 0.05 | 0.1 | μ s |
| Time jitter (see notes 7 and 10) | — | 3.0 | 5.0 | ns |
| Recovery time | see note 11 and curves | | | |
| Heater current (at 6.3V) | 9.6 | 10.6 | 11.6 | A |
| Additional tests | | | | see note 12 |

NOTES

1. The tube should preferably be clamped by the base only. Any clamps used on the bulb must not extend beyond $4\frac{1}{4}$ inches (108mm) above the top of the base and should be made from material of low thermal conductivity.
2. This is the maximum forward hold-off voltage imposed on the thyatron in a pulse modulator circuit. Tubes are tested at 18kV peak forward anode voltage, with the charging reactor inductance and pulse forming network capacitance resonant at 1000p.p.s. For instantaneous starting applications the maximum permissible peak forward voltage is 13.5kV; this must not be reached in less than 0.04 second and there must be no overshoot.
3. In pulsed operation the peak inverse anode voltage, exclusive of a spike of 0.05 microsecond duration, must not exceed 5.0kV during the first 25 microseconds after the pulse.
4. This rate of rise refers to that part of the leading edge of the pulse between 25% and 75% of the pulse amplitude.
5. Measured with respect to cathode potential.
6. All tubes are subjected to an acceleration of 10g at 50Hz before testing. In addition, samples are tested under the following conditions:
 - (a) **Linear Acceleration** 12g (min) is applied and maintained for 1 minute at right angles to and in each direction along the major axis of the tube. A heater voltage of 6.3V is applied during the test.
 - (b) **Resonance Search** Vibration is applied in two mutually perpendicular directions, one of which is parallel to the longitudinal axis of the tube. The frequency is swept at a rate not exceeding one octave per minute between 10 and 150Hz, with accelerations of $\frac{1}{4}$ g (min). All resonances detectable visually or electrically are noted for information and also for use in test (c). Normal operating voltages are applied during the test.
 - (c) **Vibration Fatigue** Each tube is subjected to vibration for two periods of ten hours. In one period the direction of vibration is parallel to the longitudinal axis of the tube, and in the other the direction is perpendicular to the longitudinal axis of the tube.

The acceleration is $\frac{1}{4}g$ and the frequency is that of the strongest resonance detected during the resonance search. If no resonances were detected in the search, then a frequency of 150Hz is used. A heater voltage of 6.3V is applied during the test.

•
Tubes must pass operational tests after the above procedure has been completed.

7. The typical figures are obtained on test using conditions of minimum grid drive. Improved performance can be expected by increasing the grid drive.
8. The time interval between a point on the leading edge of the unloaded grid pulse at 25% of the pulse amplitude and the point where anode conduction takes place.
9. Normally taken as the drift in delay time over a 5-minute run at full ratings between the second and seventh minutes of operation.
10. The variation of firing time measured at 50% of current pulse amplitude.
11. The recovery characteristics are controlled on a sampling basis.
12. In addition to operational testing at pulse repetition rates of 800 and 1000p.p.s. on all tubes, an additional test at 2500p.p.s., 12.5kV, is performed on a sampling basis.

X-RAY WARNING

X-rays are emitted by the 8503 from the region of the anode, but the radiation is usually reduced to a safe level by the metal panels of the equipment in which the tube operates.

MAXIMUM RECOVERY CHARACTERISTICS

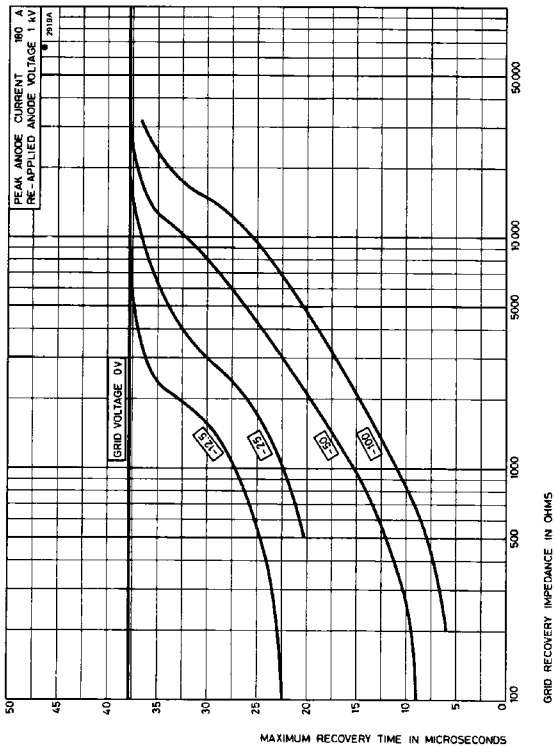

OUTLINE (All dimensions without limits are nominal)

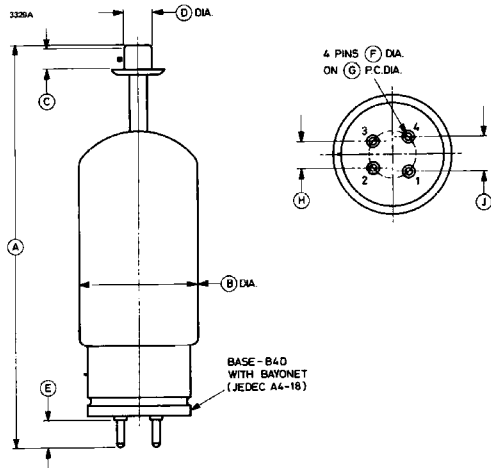

| Ref | Inches | Millimetres |
|-----|-------------------|-------------------|
| A | 8.500 ± 0.250 | 215.9 ± 6.4 |
| B | 2.563 max | 65.10 max |
| C | 0.375 min | 9.53 min |
| D | 0.566 ± 0.007 | 14.38 ± 0.18 |
| E | 0.625 | 15.88 |
| F | 0.187 ± 0.003 | 4.750 ± 0.076 |
| G | 1.000 | 25.40 |
| H | 0.562 | 14.27 |
| J | 0.750 | 19.05 |

| Pin | Element |
|---------|-----------------|
| 1 | Grid |
| 2 | Heater, cathode |
| 3 | Heater |
| 4 | Cathode |
| Top cap | Anode |

Millimetre dimensions have been derived from inches.