



5769

IMAGE ORTHONICON

Magnetic Focus
Magnetic Deflection

For Outdoor and Studio Pickup
Excellent Sensitivity

3"-Diameter Bulb
15-1/4" Length

TENTATIVE DATA

RCA-5769 is a television camera tube recommended for outdoor pickup use but it is also suitable for studio use and other applications where the illumination is not excessively low.

The 5769 is very stable in performance at all incident light levels on the object ranging from bright sunlight (several thousand foot-candles) to a deep shadow (one foot-candle or less). Commercially acceptable pictures can be obtained at light levels greater than about 50 foot-candles.

The 5769, like the RCA-5655, utilizes a photocathode characterized by a spectral response having high blue sensitivity, good green sensitivity, useful red sensitivity, and practically no infrared sensitivity. This latter characteristic of the response prevents any color-masking by infrared, and thus permits portrayal of colors in more nearly their true gradation. For the most satisfactory portrayal of colors, it is recommended that the lighting be provided by 3500 or 4500 white fluorescent lamps supplemented by tungsten illumination to provide the red.

Because of its spectral characteristics, its wide light-range capability, and its high sensitivity, the 5769 can

be substituted to advantage for the RCA-2P23 in any application where the intensity of the illumination is not excessively low. In the studio, the 5769 can be substituted for RCA-5655 to gain somewhat more freedom in set lighting by taking advantage of the greater light-range capability of the 5769, but with some sacrifice in performance because of the lower signal-to-noise ratio of the 5769.

In applications where the high sensitivity of the 5769 is not essential, as in the case of film pickup, the use of a less sensitive type of camera tube, such as RCA-1B50-A Iconoscope, is suggested.

The relatively small size of the 5769 lends itself to use in comparatively light-weight, portable television cameras, and facilitates the use of a telephoto lens with such cameras.

PRINCIPLES OF OPERATION

The 5769 has three sections—an image section, a scanning section, and a multiplier section, as shown in Fig. 1.

Image Section

The image section contains a semi-transparent photocathode on the inside of the face plate, a grid to provide an electrostatic accelerating field, and a target which consists of a thin glass disc with a fine mesh screen very closely spaced to it on the photocathode side. Focusing is accomplished by means of a magnetic field produced by an external coil, and by varying the photocathode voltage.

Light from the scene being televised is picked up by an optical lens system and focused on the photocathode which emits electrons from each illuminated area in proportion to the intensity of the light striking the area. The streams of electrons are focused on the target by the magnetic and accelerating fields.

On striking the target, the electrons cause secondary electrons to be emitted by the glass. The secondaries thus emitted are collected by the adjacent mesh screen which is held at a definite potential of about two volts with respect to target voltage cutoff. Therefore, the potential of the glass disc is limited for all values of light and stable operation is achieved. Emission of the secondaries leaves on the photocathode side of the glass a pattern of positive charges which corresponds with the pattern of light from the scene being televised. Because of the thinness of the glass, the charges set up a similar potential pattern on the opposite or scanned side of the glass.

Scanning Section

The opposite side of the glass is scanned by a low-velocity electron beam produced by the electron gun in the scanning section. This gun contains a thermionic cathode, a control grid (grid No. 1), and an accelerating grid (grid No. 2). The beam is focused at the target by the magnetic field of an external focusing coil and the electrostatic field of grid No. 4.

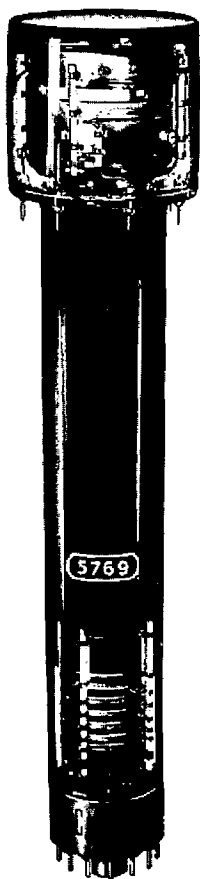

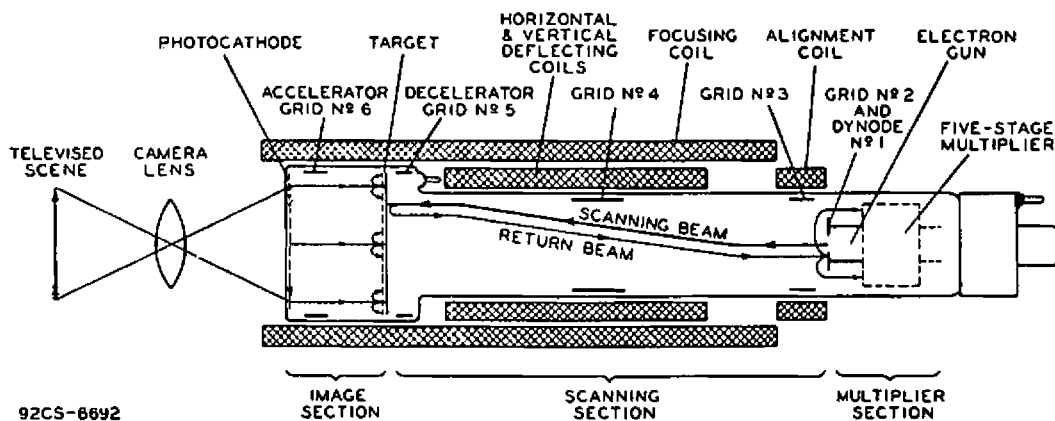

Fig. 1 - Schematic Arrangement of Type 5769.

Grid No.5 serves to adjust the shape of the decelerating field between grid No.4 and the target in order to obtain uniform landing of electrons over the entire target area. The electrons stop their forward motion at the surface of the glass and are turned back and focused into a five-stage signal multiplier, except when they approach the positively charged portions of the pattern on the glass. When this condition occurs, they are deposited from the scanning beam in quantities sufficient to neutralize the potential pattern on the glass. Such deposition leaves the glass with a negative charge on the scanned side and a positive charge on the photocathode side. These charges will neutralize each other by conductivity through the glass in less than the time of one frame.

Alignment of the beam from the gun is accomplished by a transverse magnetic field produced by an external coil located at the gun end of the focusing coil.

Deflection of the beam is accomplished by transverse magnetic fields produced by external deflecting coils.

The electrons turned back at the target form the return beam which has been amplitude modulated by absorption of electrons at the target in accord with the charge pattern whose more positive areas correspond to the highlights of the televised scene.

Multiplier Section

The return beam is directed to the first dynode of a five-stage electrostatically focused multiplier. This utilizes the phenomenon of secondary emission to amplify signals composed of electron beams. The electrons in the beam impinging on the first dynode surface produce many other electrons, the number depending on the energy of the impinging electrons. These secondary electrons are then directed to the second dynode and knock out more new electrons. Grid No.3 facilitates a more complete collection by dynode No.2 of the secondaries from dynode No.1.

The multiplying process is repeated in each successive stage, with an ever-increasing stream of electrons until those emitted from dynode No.5 are collected by the anode and constitute the current utilized in the output circuit.

The multiplier section amplifies the modulated beam about 500 times. The multiplication so obtained increases the signal-to-noise ratio of the tube and also permits the use of an amplifier with fewer stages. The gain of the multiplier is sufficiently high so that the limiting noise in the use of the tube is the random noise of the electron beam multiplied by the multiplier stages. This noise is larger than the input noise of the video amplifier.

It can be seen that when the beam moves from a less positive portion on the target to a more positive portion, the signal output voltage across the load resistor (R_{30} in Fig.2) changes in the positive direction. Hence, for highlights in the scene, the grid of the first video-amplifier stage swings in a positive direction.

DATA

General:

Heater, for Unipotential Cathode:	
Voltage (AC or DC)	6.3 ± 10% volts
Current	0.6 . . ampere
Direct Interelectrode Capacitance:	
Anode to All Other Electrodes	20 . . μm ²
Photocathode Spectral Response	See Fig.6
Image Size (3 x 4 aspect ratio)	1.6" Diagonal
Focusing Method	Magnetic
Deflection Method	Magnetic
Overall Length	15-1/4" ± 1/8"
Greatest Diameter of Bulb	3" ± 1/16"
Shoulder Base	Keyed Jumbo Annular 7-Pin
End Base	Small-Shell Diheptal 14-Pin
Mounting Position	See Text
Minimum Deflecting-Coil Inside Diameter	2-1/8"
Deflecting-coil Length	5"
Focusing-Coil Length	10"
Alignment-Coil Length	15/16"
Photocathode Distance Inside End of Focusing Coil	1/2"

Maximum Ratings, Absolute Values:

PHOTOCATHODE VOLTAGE	-550 max.	volts
PHOTOCATHODE ILLUMINATION	50 max.	ft-c
OPERATING TEMPERATURE OF ANY PART OF BULB	65 max.	°C
OPERATING TEMPERATURE OF LARGE END OF TUBE (TARGET SECTION)	35 min.	°C



TEMPERATURE DIFFERENCE:		
Between target section and any part of bulb hotter than target section . . .	- 5 max.	oC
GRID-No.6 VOLTAGE	-550 max.	volts
TARGET VOLTAGE:		
Positive value	50 max.	volts
Negative value	50 max.	volts
GRID-No.5 VOLTAGE	150 max.	volts
GRID-No.4 VOLTAGE	300 max.	volts
GRID-No.3 VOLTAGE	400 max.	volts
GRID-No.2 & DYNODE-No.1 VOLTAGE . . .	350 max.	volts
GRID-No.1 VOLTAGE:		
Negative bias value	125 max.	volts
Positive bias value	0 max.	volts
PEAK HEATER-CATHODE VOLTAGE:		
Heater negative with respect to cathode . . .	125 max.	volts
Heater positive with respect to cathode . . .	10 max.	volts
ANODE-SUPPLY VOLTAGE ^x	1650 max.	volts
VOLTAGE PER MULTIPLIER STAGE	350 max.	volts

Typical Operation and Characteristics:

Photocathode Voltage (Image Focus)	-300 to -500	volts
Grid-No.6 Voltage (Accelerator)--80% of photocathode voltage	-240 to -400	volts
Target Voltage ^o	0	volts
Grid-No.5 Voltage (Decelerator) ^{oo}	0 to 100	volts
Grid-No.4 Voltage (Beam Focus)	160 to 240	volts
Grid-No.3 Voltage [#]	225 to 330	volts
Grid-No.2 & Dynode-No.1 Voltage	300	volts
Grid-No.1 Voltage (For picture cutoff)	-45 to -115	volts
Dynode-No.2 Voltage	600	volts
Dynode-No.3 Voltage	880	volts
Dynode-No.4 Voltage	1160	volts
Dynode-No.5 Voltage	1450	volts
Anode Voltage	1500	volts
Anode Current	50	μa
Target Temperature Range (See text)	35 to 60	oC
Highlight Illumination on Photocathode for Maximum Signal Output:		
With 2870°K Tungsten Illumination	0.15	ft-c
With White Fluorescent Illumination or Daylight	0.07	ft-c
Ratio of Peak-to-Peak Highlight Video-Signal Current to RMS Noise Current (Approx.)	35	
Minimum Peak-to-Peak Blanking Voltage	10	volts
Field Strength at Center of Focusing Coil	75	gausses
Focusing-Coil Current (Approx., for coil listed below)	75	ma
Deflecting-Coil Current (Approx., for assembly listed below):		
Horizontal (Peak to peak)	625	ma
Vertical (Peak to peak)	290	ma
Alignment-Coil Current (Approx., for coil listed below)	0 to 30	ma

Components:

Deflecting-Coil Assembly (Includes Keyed Jumbo Annular 7-Pin Socket)	RCA Type No. 201D75
Focusing-Coil Assembly	RCA Type No. 202D75
Alignment-Coil Assembly	RCA Type No. 204D75
Hor. Deflection Output Transformer	RCA Type No. 204T1
Ver. Deflection Output Transformer	RCA Type No. 204T2

- x Ratio of dynode voltages is shown under Typical Operation.
- o Adjustable from -3 to +5 volts with blanking voltage off.
- oo Taps at 0, 30, 60, and 90 volts are recommended. Set at voltage giving most uniform resolution and signal output over entire picture area.
- # Adjust to give the most uniformly shaded picture near maximum signal.

INSTALLATION

The end-base pins of the 5769 fit the diheptal 14-pin socket; the annular-base pins fit the keyed jumbo annular-7-pin socket which is part of the deflecting-coil assembly having RCA type No. 201D75.

The 5769 has three complementary guides for inserting the tube correctly in the annular socket, i.e., the large pin (No.7) on the annular base, the white radial line on face of bulb, and a white longitudinal line on neck. Designers of equipment should position the annular socket so that pin No.7 of the annular base, and the white radial line when viewed from the face end of the tube, will be at the bottom of the face after the tube has been correctly inserted in the annular socket. The 5769 is installed by inserting the diheptal-base end of the tube through the coil assembly and then turning the tube until the annular-base pins, keyed by pin No.7, can be inserted in the annular socket. Proper insertion aligns the white radial line on the face with center of the slot in the annular socket, and makes the longitudinal line on the neck visible through the sight hole in the deflecting-coil assembly. The annular-base pins are then pushed into their socket, and the diheptal socket is put on the 14-pin base.

The operating position of the 5769 should preferably be such that any loose particles in the neck of the tube will not fall down and strike or become lodged on the target. Therefore, it is recommended that the tube never be operated in a vertical position with the diheptal-base end up nor in any other position where the axis of the tube with base up makes an angle of less than 20° with the vertical through the center of the base.

The operating temperature of any part of the glass bulb should never exceed 65°oC, and no part of the bulb at the large end of the tube (target section) should ever fall below 35°oC during operation. It is recommended that the temperature of the entire bulb be held between 35° and 60°oC. Operation at too low a temperature will be characterized by the appearance of a "sticking picture" of opposite polarity from the original when the picture is moved. Operation at too high a temperature will cause loss of resolution. No part of the bulb should run more than 5° hotter than the target section to prevent cesium migration to the target. Such migration will result in loss of resolution and in probable permanent damage to the tube. Like other photosensitive devices employing cesium, the 5769 may show fluctuations in performance from time to time. Strict observance of the above recommendations with respect to operating temperature will not completely eliminate these variations but will greatly improve the stability of the characteristics during the life of the tube.

When the equipment design or operating conditions are such that the maximum temperature rating or maximum temperature difference as given under Maximum Ratings will be exceeded, provision should be made to direct a stream of cooling air from the diheptal-base end of the tube along the entire length of the bulb surface, i.e., through the space between the bulb surface and the surrounding deflecting coil and its extension.

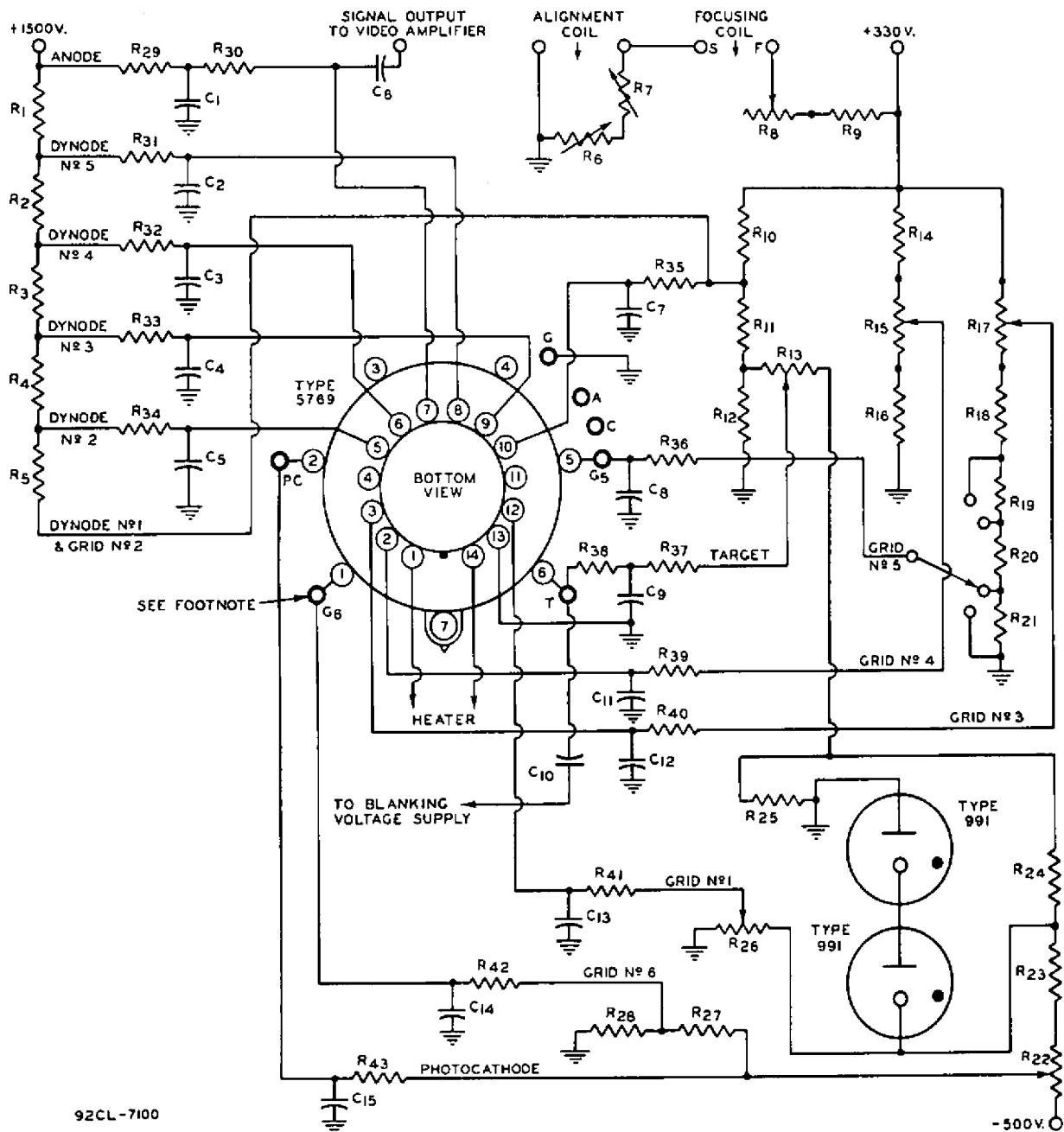

92CL-7100

○ = Terminals on Deflecting-Coil Assembly, RCA Type No. 201D75. These terminals are connected to annular socket within the Assembly as shown, except for those marked G, A, and C. G is connected to yoke shielding. A and C are connected to heater terminals on face of annular socket. Other terminals on the Assembly not shown above are indicated in Figs. 3 and 4.

Fig. 2 - Voltage Dividers for Type 5769 with Connections for: Alignment Coil, RCA Type No. 204D75, and Focusing Coil, RCA Type No. 202D75.



Any attempt to effect cooling of the tube by circulating even a large amount of air around the focusing coil will do little good, but a small amount of air directly in contact with the bulb surface will effectively drop the bulb temperature. For this purpose, a small blower is satisfactory, but it should run at low speed to prevent vibration of the 5769 and the associated amplifier equipment. Unless vibration is prevented, distortion of the picture may occur.

To keep the operating temperature of the large end of the tube from falling below 35°C, some form of controlled heating should be employed. Ordinarily, adequate heat will be supplied by the focusing coil, deflecting coils, and associated amplifier tubes so that the temperature can be controlled by the amount of cooling air directed along the bulb surface. If, in special cases, a target heater is required, it should fit snugly between the focusing coil and the bulb near the shoulder of the tube. Such a target heater is included in the RCA Deflecting-Coil Assembly.

The lens system used with the 5769 should be designed according to basic optical principles and should incorporate an iris to control the amount of light entering the television camera lens. Because of the relatively small face diameter of the 5769, the use of a telephoto lens is facilitated. The lens holder should have all inside surfaces finished in matte black to prevent internal reflections from reaching the photocathode.

For the high dc voltages required by the 5769, the use of two pulse supplies for which the plate voltage is provided by a well-regulated, 330-volt, B-supply may be used. Each of these supplies should be actuated by the horizontal driving pulse which is obtained from the synchronizing generator. One of the pulse supplies should be capable of furnishing 1500 volts with an output current of 1 milliamperes for the multiplier section; the other pulse supply should be capable of furnishing -500 volts with an output current of 1 milliamperes for the image section. In addition to sup-

plying the plate voltage and current for the pulse supplies, the 330-volt B-supply should also provide an output current of 90 milliamperes for the focusing and alignment coils and for the voltage divider which is used to supply the voltages for the electrodes in the scanning section of the 5769.

Voltage dividers to provide the required operating voltages for the various electrodes of the 5769 are shown in Fig. 2. It is to be noted that the blocking capacitor C_6 should be of the mineral-oil impregnated type to minimize capacitor leakage which will introduce disturbing effects into the picture.

In designing a voltage divider for the multiplier stages of the 5769, engineers should recognize that the dc output of individual 5769's may have a range of 10 to 1. This range, therefore, must be considered in the choice of bleeder-resistor values. If the values are too high, the distribution of voltages applied to the dynodes will be upset by a 5769 with a dc output at the upper end of the range. As a result, there will be an abrupt drop in the ac output of the tube as the beam current is increased. When this drop occurs before the beam is at its optimum value, the ratio of signal to noise will be lessened.

A horizontal deflection circuit for use with the 5769 is shown in Fig. 3; and a vertical deflection circuit in Fig. 4.

The video amplifier should be designed to cover a range of ac signal voltages corresponding to signal-output currents of 3 to 30 microamperes in the load resistor (R_{30} in Fig. 2).

APPLICATION

Resolution of better than 400 lines at the center of the picture can be produced by the 5769 when the photocathode highlight illumination from an RMA Standard Test Chart is above the knee of each of the curves in Fig. 5. To utilize such resolution capability in the horizontal direction with the standard scanning rate of 525 lines, it

LEGEND FOR FIG. 2

C1 C2: 0.05 μ f, 1600 v working voltage
C3: 0.01 μ f mica, 1600 v working voltage
C4: 0.001 μ f mica, 1000 v working voltage
C5: 0.001 μ f mica, 600 v working voltage
C6: 0.03 μ f mineral-oil impregnated,
1600 v working voltage
C7 C8 C9 C11
C12 C13 C14: 0.001 μ f mica, 400 v
working voltage
C10: 1 μ f, 400 v working voltage
R1: 47000 ohms, 1/2 watt
R2 R3: 270000 ohms, 1/2 watt
R4 R5: 300000 ohms, 1/2 watt
R6: 100 ohms, 1/2 watt, wire wound
R7: 20 ohms, 1 watt, wire wound
R8: 2500 ohms, 25 watts
R9: 750 ohms, 10 watts
R10: 5100 ohms, 1/2 watt
R11: 51000 ohms, 2 watts
R12: 510 ohms, 1/2 watt
R13: 150000-ohm potentiometer, 1/2 watt

R14: 820000 ohms, 1/2 watt
R15: 100000-ohm potentiometer, 1 watt
R16: 150000 ohms, 1/2 watt
R17: 100000-ohm potentiometer, 1 watt
R18: 56000 ohms, 1/2 watt
R19 R20 R21: 20000 ohms, 1/2 watt
R22: 250000-ohm potentiometer, 1 watt
R23: 180000 ohms, 1/2 watt
R24: 390000 ohms, 1/2 watt
R25: 11000 ohms, 1/2 watt
R26: 500000-ohm potentiometer, 1 watt
R27: 110000 ohms, 1/2 watt
R28: 560000 ohms, 1/2 watt
R29: 47000 ohms, 1/2 watt
R30: 20000 ohms, 1/2 watt
R31 R32: 100000 ohms, 1/2 watt
R33 R34 R36 R37
R39 R40 R41 R42 R43: 200000 ohms,
1/2 watt
R35: 50000 ohms, 1/2 watt
R38: 100000 ohms, 1/2 watt



is necessary to use a video amplifier having a bandwidth of at least 5.5 megacycles. The maximum resolution obtainable is limited by the mesh-screen portion of the target.

Even with a wide-band amplifier, the resolution may be limited by "cross talk" caused by the scanning fields. Unless prevented by proper shielding from extending into the image section,

If equipment space will not accommodate the full seven layers of shielding as described above, fewer layers can be used, but will be less effective in minimizing "cross talk".

The sequence of adjustments in operating the 5769 is as follows: After the tube has been inserted in its sockets and the voltages applied as indicated under Typical Operation, allow it

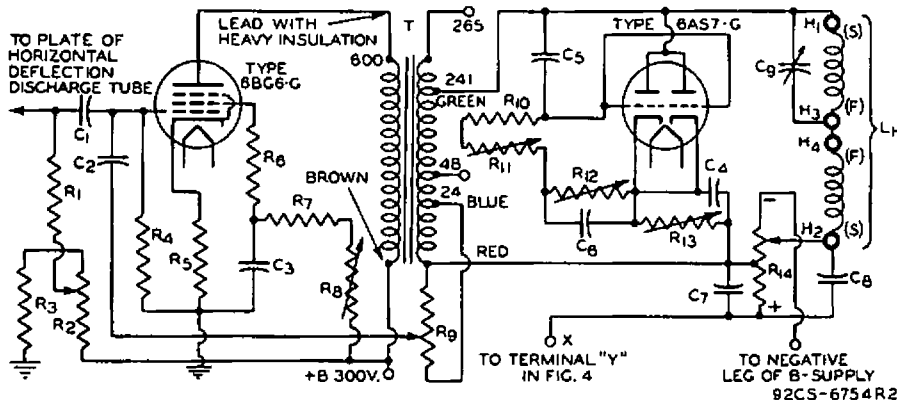

- C1: 0.01 μ f
- C2: 150 μ f
- C3 C4: 4 μ f
- C5: 30 μ f
- C6: 0.02 μ f
- C7 C8: 100 μ f
- C9: Balancing Capacitor, 10 to 40 μ f
- LH: Horizontal Deflecting Coils: Terminals H1, H2, H3, and H4 on Deflecting-Coil Assembly, RCA Type No. 201075. LH has inductance of 5.5 mh and dc resistance of 19 ohms.

- R1: 1 Megohm
- R2: Sawtooth Amplitude and Linearity Control, 250000 ohms
- R3 R4: 250000 ohms
- R5: 100 ohms, 2 watts
- R6: 100 ohms
- R7: 3000 ohms, 2 watts
- R8: 10000 ohms, 2 watts, value should be such that screen input of the 6BG6-G will not be exceeded.
- R9: Peaking Amplitude and Linearity Control, 5000 ohms
- R10: 50000 ohms, 1 watt

- R11: Linearity Control, 250000 ohms
- R12: Linearity Control, 100000 ohms
- R13: Linearity Control, 500 ohms, 5 watts
- R14: Centering Control, 10 ohms tapped at 5 ohms
- T: Horizontal Deflection Output Transformer, RCA Type No. 204T1, DC resistance of used portion of secondary is 3.4 ohms

Fig. 3 - Horizontal Deflection Circuit for Type 5769.

these fields will cause the electron image on the target to move at scanning frequency. As a result, the picture will lack definition.

Proper shielding will be provided by a shield which employs seven separate layers of silicon-steel strips (0.007" thick and 1/2" wide) applied to the outside of the focusing coil as follows: First, wrap a single insulating layer of 0.005" thick motor paper around the focusing coil; then, wrap two turns one above the other of the silicon-steel strip repeating the operation to fill the entire focusing-coil length but allowing 1/64" between each successive 2-turn section, to insure electrical insulation. Second, wrap a second insulating layer of motor paper and repeat the silicon-steel strip operation but space the 2-turn sections so that each is directly over a 1/64" insulating space of the previous layer. Operations 1 and 2 are repeated to provide 7 layers of shielding. The entire assembly is completed with a final wrap of motor paper. A convenient method for handling the 2-turn strip sections is to cut the strips just long enough to take care of two turns. Each 2-turn section is, of course, completely independent of any other section.

to warm up for 1/2 to 1 hour with the camera lens iris closed. Make certain that the deflection circuits are functioning properly to cause the electron beam to scan the target. Adjust the deflection circuits so that the beam will "over-scan" the target, i.e., so that the area of the target scanned is greater than its sensitive area. This procedure during the warming-up period is recommended to prevent burning on the target a raster smaller than that used for on-the-air operation. Note that overscanning the target results in a smaller than normal picture on the monitor. Then open the iris partially and focus the scene to be televised on the photocathode. Next, adjust the grid-No. 1 voltage until a picture or noise appears on the monitor screen. If there is no picture, rotate the alignment coil until the picture appears and then adjust the current through the alignment coil until the maximum picture response is obtained. Correct alignment is obtained when the picture does not rotate as the beam-focus control (grid No. 4) is varied. During alignment of the beam, and during operation of the tube, always keep the beam current as low as possible to give the best picture quality. Next, adjust grid-No. 1 voltage and the



target voltage for the best picture. Then, bring the picture into focus by varying the voltage on grid No.4 and on the photocathode. Next, vary the voltage on grid No.3 to give the most uniformly shaded picture at approximately maximum signal. Final adjustment is made by varying the voltages on grids No.5 and No.6. In general, these need little adjustment and are varied only

and its multiplied output flows through the load resistance.

Shading may be required even with optimum adjustment of voltage on grid No.3 in order to obtain a uniformly shaded picture. A shading signal having a sawtooth shape, a frequency equal to the horizontal scanning frequency, and an amplitude about twice that of the useful video

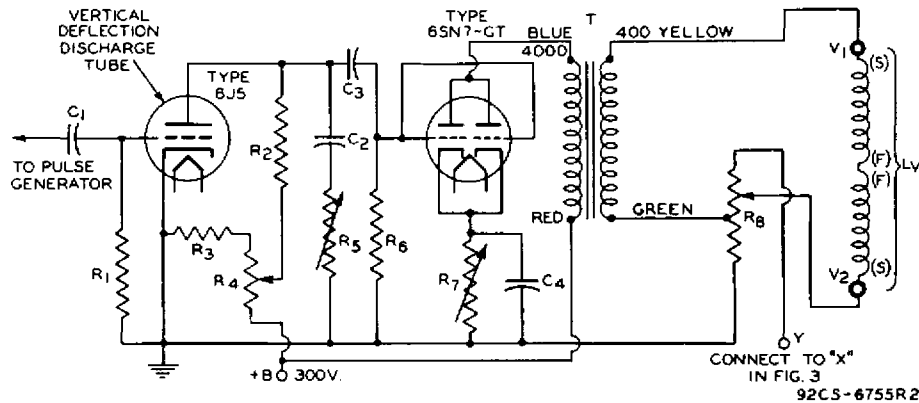

- | | | |
|---------------------------------|---------------------------------|--------------------------------------|
| C1: 0.1 μ f | 28.3 mh, and dc resistance of | R6: 500000 ohms |
| C2: 0.05 μ f | 34 ohms. | R7: Linearity Control, 5000 ohms |
| C3: 1 μ f | R1: 1 megohm | R8: Centering Control, 10 ohms |
| C4: 1000 μ f | R2: 5 megohms | tapped at 5 ohms |
| LV: Vertical Deflecting Coils: | R3: 100000 ohms | T: Vertical Deflection Output Trans- |
| Terminals V1 and V2 on Deflect- | R4: Sawtooth Amplitude Control, | former, RCA Type No. 204T2. DC |
| ing Coil Assembly, RCA Type No. | 250000 ohms | resistance of secondary is |
| 201D75. LV has inductance of | R5: Peaking Amplitude Control, | 6.9 ohms. |
| | 250000 ohms | |

Fig. 4 - Vertical Deflection Circuit for Type 5769.

after completing the other adjustments. When camera is used for rehearsal, the scanning may be restored nearly to normal size. Complete restoration should be made just prior to air-time.

The target voltage will depend on the type of scene to be televised. If the scene has a large range of illumination (such as that for a baseball game on a sunny day), the target should be operated at about 1.5 to 2 volts above cutoff so that highlights will not bloom. For scenes with a lower range of illumination (such as that for a boxing match under artificial lighting), the target can be operated at about 2 to 3 volts above cutoff with resultant gain in signal-to-noise ratio, and improved detail in the shadows.

A blanking signal should be supplied to the target to prevent the electron beam from striking the target during the return portions of the horizontal and vertical deflecting cycles. Unless this is done, the camera-tube return lines will appear in the received picture.

The blanking signal is a series of negative voltage pulses. The voltage between pulses must be constant to prevent fluctuation of the target voltage. During the blanking periods, the full beam current without video-signal modulation is returned to the multiplier

signal, is recommended. Provision should be made for controlling the amplitude of the shading signal and for reversing its polarity. The signal may be introduced into the video channel after the preamplifier in the camera but ahead of the master gain control. With this arrangement, changing the gain-control setting does not change the ratio of the shading-signal amplitude to the video-signal amplitude.

The illumination on the photocathode is related to the scene illumination by the formula

$$I_s = \frac{4f^2 I_{pc} (m+1)^2}{TR}$$

where

- I_s = scene illumination in foot-candles
- f = f-number of lens
- I_{pc} = photocathode illumination in foot-candles
- m = linear magnification from scene to target
- T = total transmission of lens
- R = reflectance of principal subject in scene.

Except for very close shots, the linear magnification (m) from scene to target may be neglected.

For example, assume that the lens is f:3.5 having a transmission (T) of 75%, that the photocathode illumination from a tungsten source is 0.15 foot-candle, and that the scene to be tele-

vised is composed largely of whites and blacks (such as a test chart) where the reflectance (R) may be in the order of 50%. Then,

$$I_s = \frac{4 \times 3.5^2 \times 0.15}{0.75 \times 0.50} = 20 \text{ ft-c approx.}$$

In practice, and under the assumed conditions of the preceding example, it will be found that the required minimum illumination on the scene will be in the range from 10 to 30 foot-candles.

light or daylight, the knee may occur at values of highlight illumination on the photocathode ranging from about 0.05 to 0.1 foot-candle; with tungsten light, the knee may occur in the range from about 0.1 to 0.2 foot-candle.

When colors are televised, the most satisfactory gradation in black and white will be obtained when white fluorescent illumination is augmented by tungsten floodlights. The exact

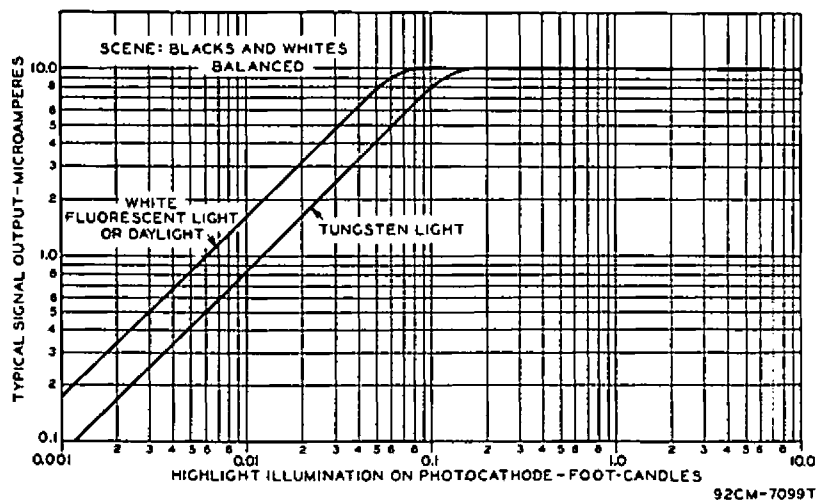

Fig. 5 - Typical Signal Output of Type 5769.

For average scenes where the principal subject has a reflectance of 5 to 10%, the incident illumination should have a value of 50 to 100 foot-candles.

It is good practice before attempting to transmit a particular scene to check its incident illumination with an illumination-measuring device, such as an exposure meter. It is recommended that the average incident light level be greater than approximately 50 foot-candles for a good picture. If white fluorescent or daylight illumination is used, the incident light level may be as low as 25 foot-candles.

Typical signal output of the 5769 as a function of the highlight illumination on the photocathode under conditions where the televised scene has balanced blacks and whites for each of three types of illumination is shown by the curves in Fig. 5.

For the most natural appearance of televised subjects, it is recommended that the 5769 be operated so that the highlights on the photocathode bring the signal output slightly over the knee of the curve for the particular type of illumination utilized. Operation further along on the straight part of the curve will give pictures in which the subject has an over-emphasized outline. The position of the knee will shift for individual tubes. With white fluorescent

proportion of tungsten to fluorescent illumination will vary with desired results and can best be determined by trial.

The spectral response of the 5769 is not subject to appreciable variation from tube to tube. The spectral response is shown by the curve in Fig. 6.

Retention of a scene by the 5769, sometimes called a "sticking picture", may be experienced if the 5769 is allowed to remain focused on a bright scene for an hour or more, or if it is focused on a bright scene before reaching operating temperature in the range from 35° to 60°C. Often the retained image will disappear in a few seconds, but sometimes it may persist for long periods before it completely disappears. A retained image can generally be removed by focusing the 5769 on a clear white screen, and allowing the 5769 to operate for several hours with an illumination of about 1 foot-candle on the photocathode.

To avoid retention of a scene, it is recommended that the 5769 always be allowed to warm up in the camera for 1/2 to 1 hour with the lens iris closed, and that the 5769 never be allowed to remain focused on a stationary bright scene for an hour or more. If a target heater is used, the warm-up time can be reduced to approximately 10 or 15 minutes.



Failure of scanning even for only a few minutes when light is incident on the photocathode, may permanently damage the surface of the target. The damaged area shows up as a spot or line in the picture during subsequent operation.

To avoid damaging the 5769 during scanning failure, provision should be made to prevent automatically the scanning beam from reaching the target. The scanning beam can be prevented from reaching the target by (1) cutting off the scanning beam, or (2) making the target sufficiently negative. The scanning beam can be cut off by a relay which applies -115 to -125 volts bias to grid No. 1. The target can be made sufficiently negative by a relay which applies a bias of at least -10 volts to it. Either relay is

actuated by a tube which is controlled by a portion of the scanning pulse voltage developed across either the horizontal or the vertical deflecting coils, or both. It is important to insure that the horizontal scanning pulse and the vertical scanning pulse should each independently actuate the relay in case either one fails.

Rotation in the use of 5769's is recommended. After a 5769 is operated for 200 to 300 hours, it should be given an idle period of 3 or 4 weeks during which it generally will recover much of its original resolution and sensitivity. Spare tubes should be placed in service for several hours at least once a month in order to keep them free from any traces of gas which may be liberated within them during prolonged storage.

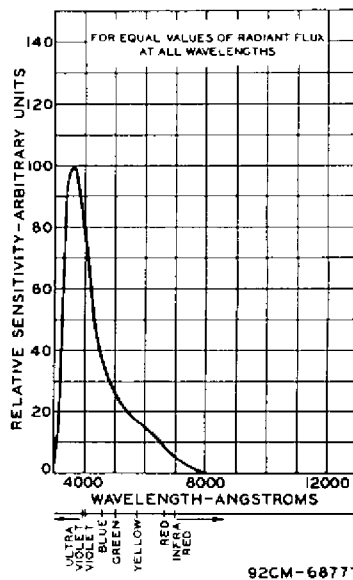
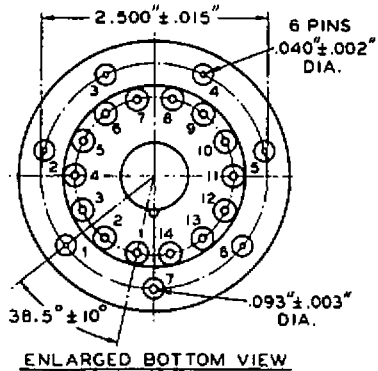
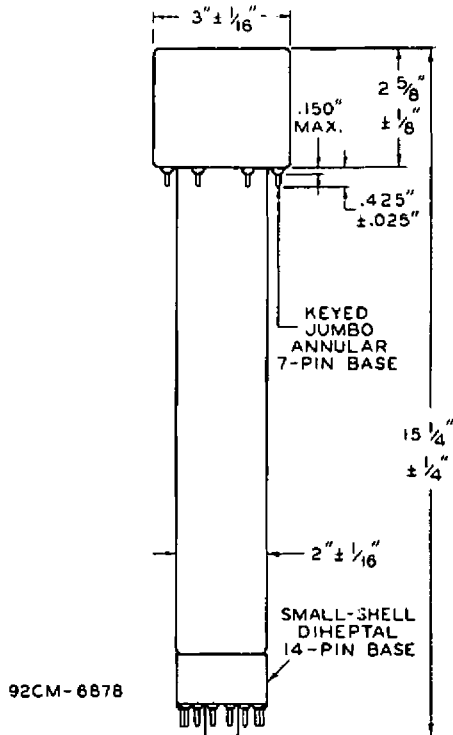

Fig. 6 - Spectral Sensitivity Characteristic of Type 5769.

Devices and arrangements shown or described herein may use patents of RCA or others. Information contained herein is furnished without responsibility by RCA for its use and without prejudice to RCA's patent rights.



DIMENSIONAL OUTLINE



ENLARGED BOTTOM VIEW

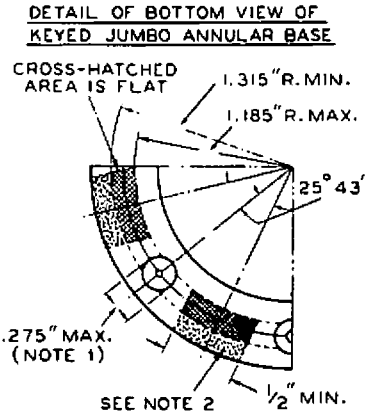

NOTE 1: MEASURED AT DISTANCE OF $\frac{1}{32}$ " BELOW BOTTOM OF ANNULAR BASE.

NOTE 2: DOTTED AREA IS FLAT OR EXTENDS TOWARD DIHEPTAL-BASE END OF TUBE BY $0.060"$ MAX.

KEYED ANNULAR BASE GAUGE

ANGULAR VARIATIONS BETWEEN PINS AS WELL AS ECCENTRICITY OF NECK CYLINDER WITH RESPECT TO PHOTOCATHODE CYLINDER ARE HELD TO TOLERANCES SUCH THAT PINS AND NECK CYLINDER WILL FIT FLAT-PLATE GAUGE WITH:

- a. SIX HOLES HAVING DIAMETER OF $0.065" \pm 0.001"$ AND ONE HOLE HAVING DIAMETER OF $0.150" \pm 0.001"$. ALL HOLES HAVE DEPTH OF $0.265" \pm 0.001"$. THE SIX $0.065"$ HOLES ARE ENLARGED BY 45° TAPER TO DEPTH OF $0.047"$. ALL HOLES ARE SPACED AT ANGLES OF $51^\circ 26' \pm 5'$ ON CIRCLE DIAMETER OF $2.500" \pm 0.001"$.
- b. SIX STOPS HAVING HEIGHT OF $0.187" \pm 0.001"$, CENTERED BETWEEN PIN HOLES, TO BEAR AGAINST FLAT AREAS OF BASE.
- c. RIM EXTENDING OUT A MINIMUM OF $\frac{1}{8}"$ FROM $2\text{-}\frac{13}{16}"$ DIAMETER AND HAVING HEIGHT OF $0.126" \pm 0.001"$.
- d. NECK-CYLINDER CLEARANCE HOLE HAVING DIAMETER OF $2.200" \pm 0.001"$.



SOCKET CONNECTIONS

Bottom View

DIRECTION OF LIGHT:
PERPENDICULAR TO
LARGE END OF TUBE

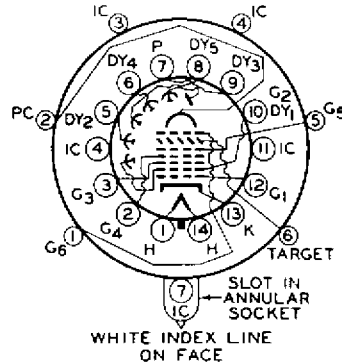

SMALL-SHELL DIHEPTAL 14-PIN BASE

PIN 1: HEATER	PIN 9: DYNODE No. 3
PIN 2: GRID No. 4	PIN 10: DYNODE No. 1, GRID No. 2
PIN 3: GRID No. 3	PIN 11: INTERNAL CONNEC- TION - DO NOT USE
PIN 4: INTERNAL CONNEC- TION - DO NOT USE	PIN 12: GRID No. 1
PIN 5: DYNODE No. 2	PIN 13: CATHODE
PIN 6: DYNODE No. 4	PIN 14: HEATER
PIN 7: ANODE	
PIN 8: DYNODE No. 5	

KEYED JUMBO ANNULAR 7-PIN BASE

PIN 1: GRID No. 6	PIN 5: GRID No. 5
PIN 2: PHOTOCATHODE	PIN 6: TARGET
PIN 3: INTERNAL CONNEC- TION - DO NOT USE	PIN 7: INTERNAL CONNEC- TION - DO NOT USE
PIN 4: INTERNAL CONNEC- TION - DO NOT USE	