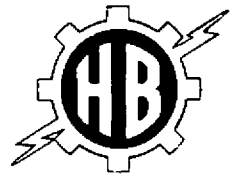

**HAYDU**

engineering data report

**6700**

## Magnetron Beam Switching Tube (MO-10)

### HIGH VACUUM, TEN OUTPUT

BEAM SWITCHING TUBE  
Type - 6700

**ELECTRICAL**

Heater, Voltage .....	6.3 $\pm$ 10% V AC or DC
Current .....	0.3 A.

**MECHANICAL, See Figure 1**

Overall length .....	3.000" max.
Seated height .....	2.750" max.
Base seat to hold-down line .....	2.500" max.
Bulb diameter .....	1.125" max.
Magnet, diameter, without protective caps .....	1.600" max.
Magnet, diameter, with protective caps .....	1.710" max.
Magnet, length, without protective caps .....	1.750" max.
Magnet, length, with protective caps .....	1.950" max.
Envelope connections .....	see figure 2
Socket, 26 pin, (Haydu No. HSK-100) .....	see figure 3
Weight, total .....	7.5 ozs.
Mounting Position .....	any

**INTERELECTRODE CAPACITANCES (typical)**

Any spade to all other elements (including heater) .....	5uuf
Any target to all other elements (including heater) .....	5uuf
Odd grids (5) to all other elements (including heater) .....	10uuf
Even grids (5) to all other elements (including heater) .....	10uuf
Cathode to all other elements (including heater)	8uuf

**MAXIMUM RATINGS**

Target voltage .....	300 V
Spade voltage .....	300 V
Grid voltage .....	300 V
Heater-cathode voltage .....	$\pm$ 90 V
Individual target dissipation .....	1 watt
Switching Speed .....	From static to above 1 Mc.

**TYPICAL OPERATING CONDITIONS AND CHARACTERISTICS**

Target voltage .....	100 V d.c.
Target, individual output current .....	7.5 ma. see note 1
Target, output current uniformity (10 targets)	$\pm$ 10%
Target Load Resistor .....	3.3 K ohms
Cathode current .....	9.0 ma.
Spade voltage .....	100 $\pm$ 10% V d.c. see note 2
Spade current .....	1.5 ma.
Spade load resistor .....	100 K ohms
Grid voltage .....	+25 V d.c.
Grid input pulse amplitude .....	-50 V see note 3 and 4
Grid current .....	0.05 ma.
Switching speed .....	0.2 micro-sec.
Cut-off voltage (all spades common) .....	+200 V see note 2

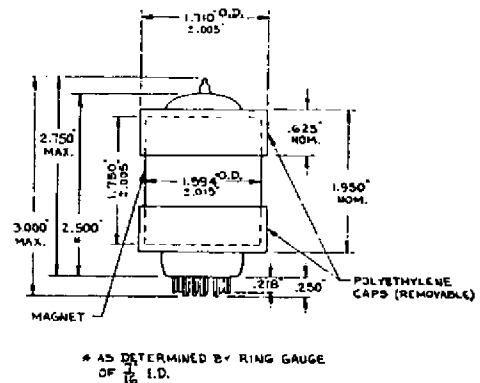

Figure 1  
Outline Drawing

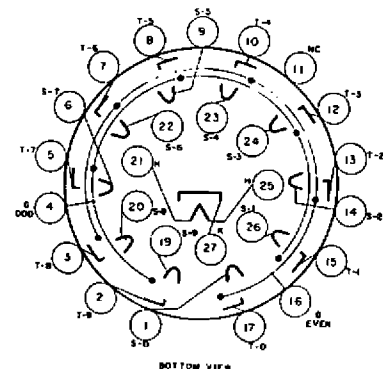

Figure 2  
Envelope Connection Diagram

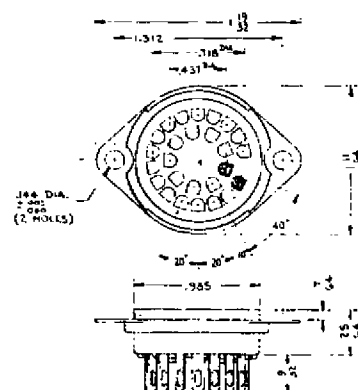

Figure 3  
Contact Socket Assembly



**NOTE 1.**  
**OUTPUT**

Approximately 90% of the beam is available in producing an output with the pentode type characteristic of Figure 4. The remainder is used to automatically form and lock the beam in position. This is obtained without suppression, and a wide variety of target resistor load lines can intersect the constant current portion of the curve with negligible crosstalk.

**NOTE 2.**  
**THE CLEAR POSITION AND BEAM FORMATION**

When the potential of all the spades is positive, the tube is in a cut-off or clear condition with no beam formed to any position. The beam may be formed in any of its ten "on" positions by sufficiently lowering the potential of the respective spade. A typical static beam forming and locking characteristic is shown in Figure 5, intercepted by a load line of  $R_s = 100 K$ . This negative characteristic results in bistable points at A and C. Thus, the one spade forming and locking the beam is at near-cathode potential, point A, while the remaining ones are at a high positive level. In practice, either a DC potential or a very high speed pulse may be used to form the beam. The very wide range of reliability of the function of  $R_s$  is indicated in Figure 5.

**NOTE 3.**  
**GRID SWITCHING**

When a beam has been formed on a spade it can remain there indefinitely, or it can be advanced by lowering the switching grid voltage.

A voltage drop on the switching grid will disturb the electric field so that enough of the beam is deflected to the leading spade to cause that spade to assume its other stable state (A). The beam will now be formed on this spade with the dynamic spade characteristic shown in Figure 5.

Because of their shape and position, the grid electrodes effect a very uniform switching. This dynamic action is in the order of 0.2 micro-second, and draws negligible current.

In each position, the beam is only affected by the individual grid with which it is associated. The grids are connected in two groups, the odd numbered grids in one group and the even numbered in the other. In this way it is possible to use a DC input and still secure single position stepping.

**NOTE 4.**  
Switching input can be D.C., sine-wave or pulsed.

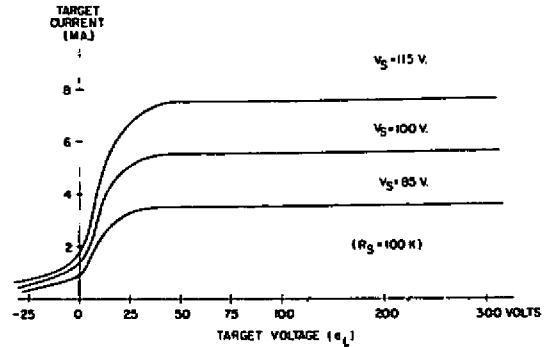

*Figure 4*  
Output characteristic

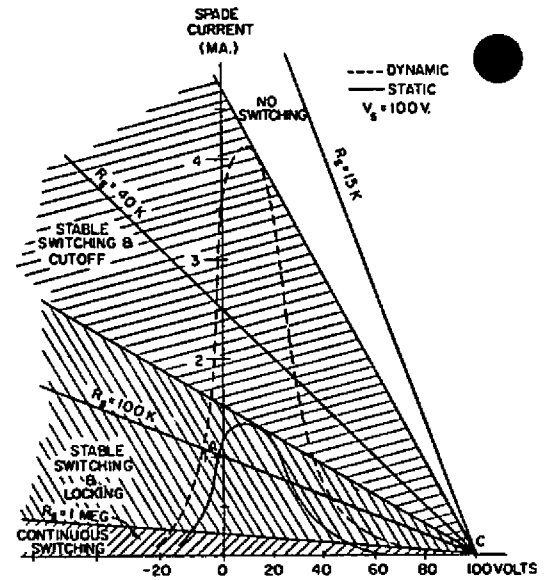

*Figure 5*  
Beam Forming & Locking Spade Characteristic

**HAYDU**  
BROTHERS OF NEW JERSEY  
*Plainfield, New Jersey*

SUBSIDIARY OF BURROUGHS CORPORATION

An Applications Engineering Department, offering engineering service and consultation, has been set up to assist you in taking full advantage of this device. For further information, contact

APPLICATIONS ENGINEERING DEPARTMENT  
HAYDU BROTHERS OF NEW JERSEY  
c/o BURROUGHS RESEARCH CENTER  
PAOLI, PENNSYLVANIA